

Quick-fitting Type Shut-off Valve Ball Valve

Features

- The Ball Valve turns on and off the air pressure to pneumatic equipment.
- It provides effective sectional area appropriate to the tube size.
- The graduations on the lever enables rough adjustments of flow rate (10 series).
- Water can be passed because of PPS used for the body resin (20, 60 series).

Construction

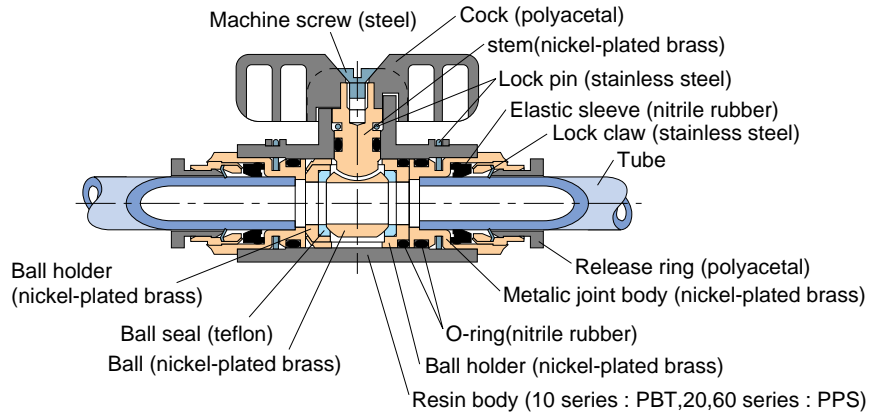

Specification

Series	10 Series	20 Series	60 Series
Fluid admitted	Air	Air, water (conditional)	
Service pressure range	0~100psi(0~0.7MPa)	0~150psi(0~0.9MPa)	
Working vacuum	-29.5in. Hg	-100KPa	
Service temperature range	32~140°F	0~60°C	
Effective cross-sectional area	10mm ² (0.542Cv)	20mm ² (1.084Cv)	60mm ² (3.252Cv)

⚠ Warning

*Conditions of Water (when used)

1. Operating temperature : 32~140°F(0~60°C)
2. Operating pressure : 0~43.5psi(0~0.3MPa)
3. No water hammer is allowed.
4. Be sure to install the insert ring.

Model Designation (Example)

BVC **20** = **06** **01** **(5)**

(1) Type

(2) Effective cross-sectional area

Code	No code	20	60
Effective cross-sectional area	10mm ²	20mm ²	60mm ²

(3) Port size

Port size	Tube dia (mm)					in. size			
Code	04	06	08	10	12	1/4	5/16	3/8	1/2
Size	φ4	φ6	φ8	φ10	φ12	φ1/4	φ5/16	φ3/8	φ1/2

Port size	Taper pipe thread				American standard Taper pipe thread			
Code	01	02	03	04	N1	N2	N3	N4
Size	R1/8	R1/4	R3/8	R1/2	NPT1/8	NPT1/4	NPT3/8	NPT1/2

(4) Port size

Port size	Tube dia (mm)					in. size			
Code	04	06	08	10	12	1/4	5/16	3/8	1/2
Size	φ4	φ6	φ8	φ10	φ12	φ1/4	φ5/16	φ3/8	φ1/2

Port size	tube dia (mm)					in. size				Taper pipe thread				American standard Taper pipe thread			
Code	04	06	08	10	12	1/4	5/16	3/8	1/2	01	02	03	04	N1	N2	N3	N4
Size	φ4	φ6	φ8	φ10	φ12	φ1/4	φ5/16	φ3/8	φ1/2	R1/8	R1/4	R3/8	R1/2	NPT1/8	NPT1/4	NPT3/8	NPT1/2

Application example

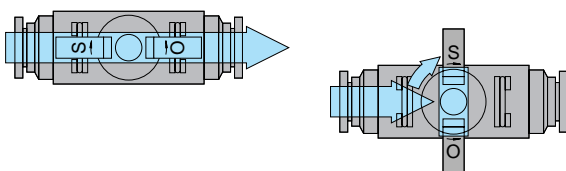

(5) Hexagon flat-to-flat specification

U: Hexagon flat-to-flat inch spec. (NPT)
No code: Hexagon flat-to-flat mm spec.

- Either of the ports can be an air inlet port.
Turn the lever in O direction and air flows.
Turn the lever to the end stop in S direction and air stops.

 **Detailed Safety Instruction**

Before using the PISCO device, be sure to read the "Safety Instructions", "Common Safety Instructions for Products Listed in This Manual" on page 23~24 and "Common Safety Instructions for Change Series Valves" on page 279.

 **Warning**

1. When the fluid admitted is water, do not use the 20 or 60 series unless all the conditions required in Specifications are satisfied. Otherwise damage to the valve body or leaks may result.

 **Caution**

1. When operating the lever, turn it 90 degrees completely until it stops. Inadequate turning may result in poor conduction or low flow rate due to faulty switching.
2. For use with negative pressures, provide a vacuum filter on the suction side. Otherwise dust sucked in may cause malfunction.
3. Do not pull out the lock pin, or the body will come off. Also, before use, make certain that the lock pin is properly in place.

Change Series Ball Valve

BVU₁₀ Union Straight

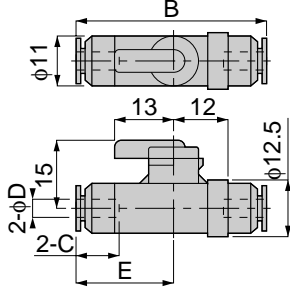

unit:mm								
Model	Tube dia. φD	B	C	E	Mass (g)	Ball I.D. (φ)	Orifice (φmm)	Eff. a. (mm ²)
BVU 4-4	4	37	9.5	17	12	4	2.5	3.4
BVU 6-6	6	40.5	12	17.5	12.5	4	4	10.3

BVG₁₀ Reducing Union Straight

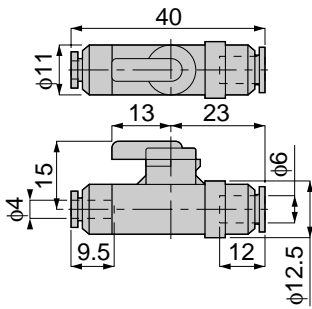

unit:mm				
Model	Mass (g)	Ball I.D. (φ)	Orifice (φmm)	Eff. a. (mm ²)
BVG 6-4	12.5	4	2.5	3.8

BVM₁₀ Bulkhead Union Straight

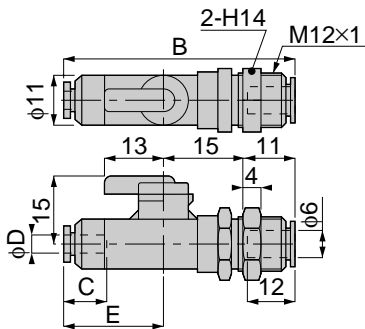

unit:mm								
Model	Tube dia. φD	B	C	E	Mass (g)	Ball I.D. (φ)	Orifice (φmm)	Eff. a. (mm ²)
BVM 6-4	4	46.5	9.5	17	16.5	4	2.5	3.8
BVM 6-6	6	47.5	12	17.5		4	4	10.3

BVC₁₀ Straight

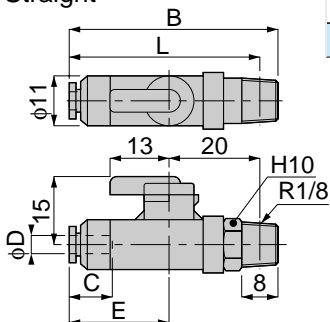

unit:mm									
Model	Tube dia. φD	B	L	C	E	Mass (g)	Ball I.D. (φ)	Orifice (φmm)	Eff. a. (mm ²)
BVC 01-4	4	41	37	9.5	17	14.5	4	2.5	3.8
BVC 01-6	6	41.5	37.5	12	17.5	15	4	4	10.5

Change Series Ball Valve

BVLU₁₀

Union Elbow

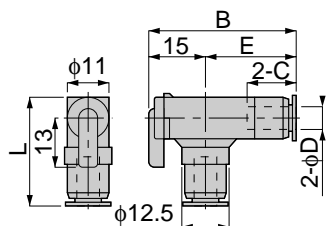

unit:mm

Model	Tube dia. φD	B	L	C	E	Mass (g)	Ball I.D. (φ)	Orifice (φmm)	Eff. a. (mm ²)
BVLU 4-4	4	36.5	26	9.5	21.5	17.5	4	2.5	4
BVLU 6-6	6	39.5	29	12	24.5	18	4	4	8



BVLG₁₀

Different Diam. Union Elbow

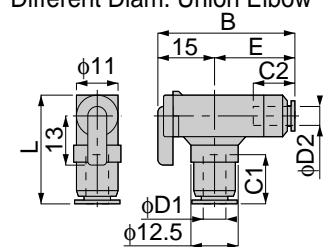

unit:mm

Model	Tube dia. φD1	Tube dia. φD2	B	L	C1	C2	E	Mass (g)	Ball I.D. (φ)	Orifice (φmm)	Eff. a. (mm ²)
BVLG 4-6	4	6	36.5	26	9.5	12	21.5	17.5	4	3.5	4
BVLG 6-4	6	4	39.5	29	12	9.5	24.5	17.5	4	3.5	4



BVLC₁₀

Elbow

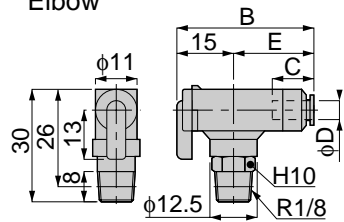

unit:mm

Model	Tube dia. φD	B	C	E	Mass (g)	Ball I.D. (φ)	Orifice (φmm)	Eff. a. (mm ²)
BVLC 4-01	4	36.5	9.5	21.5	20	4	3.5	4
BVLC 6-01	6	39.5	12	24.5	20	4	4	8



unit:inch

Model	Tube dia. φD	B	E	C	Ball I.D.	Weight (g)	Orifice φmm	Eff.a. mm ²	Cv
BVLC1/8-N1U	1/8	1.44	0.9	0.43	0.16	20.6	2.5	4.0	0.21
BVLC5/32-N1U	5/32	1.44	0.9	0.43	0.16	20.3	2.5	4.0	0.21

BVLC₁₀

Elbow

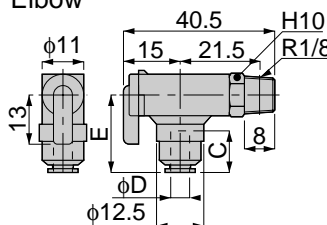

unit:mm

Model	Tube dia. φD	C	E	Mass (g)	Ball I.D. (φ)	Orifice (φmm)	Eff. a. (mm ²)
BVLC 01-4	4	9.5	20.5	20	4	3.5	4
BVLC 01-6	6	12	23.5	20	4	4	8



unit:inch

Model	Tube dia. φD	L	C	Ball I.D.	Weight (g)	Orifice φmm	Eff.a. mm ²	C v
BVLCN1-1/8U	1/8	1.02	0.4	0.16	20.5	2.5	3.8	0.20
BVLCN1-5/32U	5/32	1.02	0.4	0.16	20.5	2.5	3.8	0.20

BVLM₁₀

Bulkhead Union Elbow

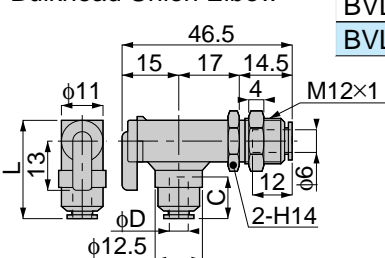

unit:mm

Model	Tube dia. φD	L	C	Mass (g)	Ball I.D. (φ)	Orifice (φmm)	Eff. a. (mm ²)
BVLM 6-4	4	26	9.5	18.5	4	3.5	4
BVLM 6-6	6	29	12	19	4	4	8



Change Series Ball Valve

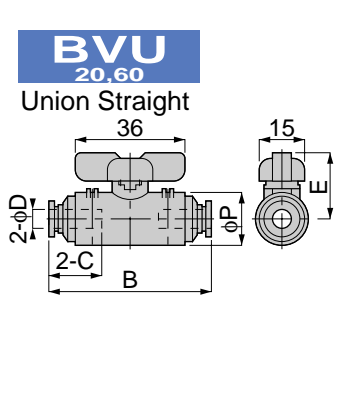

unit:mm

Model	Tube dia. φD	B	φP	C	E	Mass (g)	Orifice (φmm)	Eff. a. (mm ²)
BVU 20-0606	6	54.5	17	17	22	45	5	10.7
BVU 20-0808	8	56		18.5		6	21.7	
BVU 60-1010	10	66	24	21	25	102.5	9	41
BVU 60-1212	12	69		23.5		9		55.9

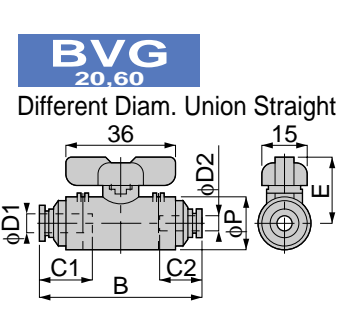

unit:mm

Model	Tube dia. φD1	Tube dia. φD2	B	φP	C1	C2	E	Mass (g)	Orifice (φmm)	Eff. a. (mm ²)
BVG 20-0806	8	6	55	17	18.5	17	22	42.5	5	13.1
BVG 60-1210	12	10	67.5	24	23.5	21	25	100.5	9	40.9

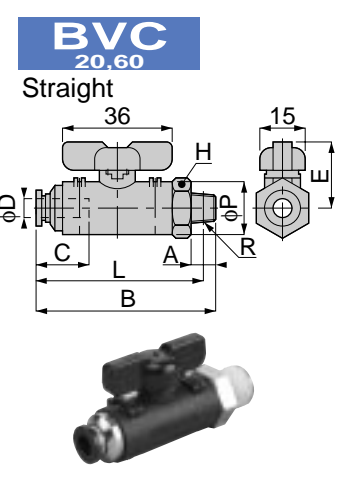

unit:mm

Model	Tube dia. φD	R	A	B	L	C	Mass (g)	Orifice (φmm)	Eff. a. (mm ²)
BVC 20-0601	6	R1/8	8	59	55	17	55.5	5	12.7
BVC 20-0602		R1/4	11	62	56		58.5		12.8
BVC 20-0603		R3/8	12	63	56.5		67.5		12.5
BVC 20-0801	8	R1/8	8	60	56	18.5	53.5	6	22
BVC 20-0802		R1/4	11	63	57		56.5		23.1
BVC 20-0803		R3/8	12	64	57.5		64.5		23.1
BVC 60-1002	10	R1/4	11	74	70	21	130	8.5	39.9
BVC 60-1003		R3/8	12	75	69		132.5	9	41.3
BVC 60-1004		R1/2	15	78	71.5		149.5	9	41.2
BVC 60-1202	12	R1/4	11	75.5	70.5	23.5	128	8.5	51.9
BVC 60-1203		R3/8	12	76.5	70.5		130.5	9	55.5
BVC 60-1204		R1/2	15	79.5	73		147.5	9	55.3



unit:inch

Model	Tube dia. φ D	NPT	A	B	L	C	φP	E	H	Weight (g)	Orifice φ mm	Eff.a. mm ²	Cv
BVC20-1/4 N1U	1/4	1/8	0.31	2.33	2.17	0.67	0.67	0.87	11/16	56.5	5.0	12.7	0.68
BVC20-1/4 N2U	1/4	1/4	0.43	2.44	2.21	0.67	0.67	0.87	11/16	59.9	5.0	12.8	0.69
BVC20-1/4 N3U	1/4	3/8	0.47	2.48	2.23	0.67	0.67	0.87	11/16	68.4	5.0	12.5	0.67
BVC20-5/16 N1U	5/16	1/8	0.31	2.36	2.21	0.73	0.67	0.87	11/16	54.4	6.0	22.0	1.19
BVC20-5/16 N2U	5/16	1/4	0.43	2.48	2.25	0.73	0.67	0.87	11/16	57.8	6.0	23.1	1.25
BVC20-5/16 N3U	5/16	3/8	0.47	2.52	2.27	0.73	0.67	0.87	11/16	66.5	6.0	23.1	1.25
BVC60-3/8 N2U	3/8	1/4	0.43	2.91	2.76	0.83	0.94	0.98	1.00	134.2	8.5	39.9	2.16
BVC60-3/8 N3U	3/8	3/8	0.47	2.95	2.72	0.83	0.94	0.98	1.00	137.0	9.0	41.3	2.23
BVC60-3/8 N4U	3/8	1/2	0.59	3.07	2.81	0.83	0.94	0.98	1.00	153.9	9.0	41.2	2.23
BVC60-1/2 N2U	1/2	1/4	0.43	2.97	2.81	0.93	0.94	0.98	1.00	130.2	8.5	51.9	2.81
BVC60-1/2 N3U	1/2	3/8	0.47	3.01	2.78	0.93	0.94	0.98	1.00	133.1	9.0	55.5	3.00
BVC60-1/2 N4U	1/2	1/2	0.59	3.13	2.87	0.93	0.94	0.98	1.00	149.8	9.0	55.3	2.99

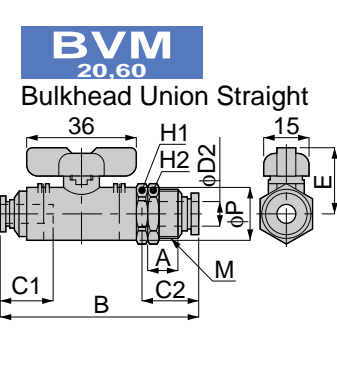

unit:mm

Model	Tube dia. φD1	Tube dia. φD2	M	A	B	φP	C1	C2	E	H1	H2	Mass (g)	Orifice (φmm)	Eff. a. (mm ²)
BVM 20-0806	6	8	M16x1	11	66	17	17	18.5	22	19	19	48	5	12.5
BVM 20-0808	8			67	18.5	22	19	19	46	6	21			
BVM 60-1210	10	12	M22x1	17	84.5	24	21	23.5	25	24	27	116	9	40.8
BVM 60-1212	12			86	23.5	25	24	27	114	10	54.6			



unit:inch

Model	Tube dia. φ D1	Tube dia. φ D2	UNF	F	B	φ P	C1	C2	E	H1	H2	L	Weight (g)	Orifice φ mm	Eff.a. mm ²	Cv
BVM20-5/16 1/4U	1/4	5/16	5/8	0.43	2.60	0.67	0.67	0.73	0.87	3/4	3/4	0.16	50.1	5.0	12.5	0.67
BVM20-5/16 5/16U	5/16	5/16	5/8	0.43	2.64	0.67	0.73	0.73	0.87	3/4	3/4	0.16	48.0	6.0	21.0	1.13
BVM60-1/2 3/8U	3/8	1/2	7/8	0.67	3.33	0.94	0.83	0.93	0.98	1.00	1.00	0.20	115.3	9.0	40.8	2.21
BVM60-1/2 1/2U	1/2	1/2	7/8	0.67	3.39	0.94	0.93	0.93	0.98	1.00	1.00	0.20	111.3	10.0	54.6	2.95

Change Series Ball Valve

BVLU 20.60

Union Elbow

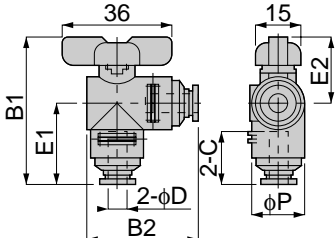

Model	Tube dia. φD	B1	B2	φP	C	E1	E2	Mass (g)	Orifice (φmm)	Eff. a. (mm ²)
BVLU 20-0606	6	49.5	37	17	17	17	22	46	5	9.6
BVLU 20-0808	8	50	38		18.5	28		41.5	6	18.1
BVLU 60-1010	10	60.5	45	24	21	35.5	25	105.5	9	33.5
BVLU 60-1212	12	62	46.5		23.5	37		101	10	44.3



unit:mm

BVLG 20.60

Different Diam. Union Elbow

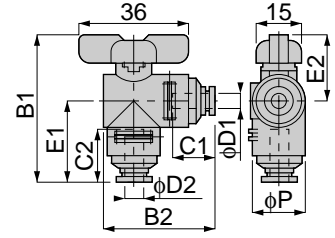

Model	Tube dia. φD1	Tube dia. φD2	B1	B2	φP	C1	C2	E1	E2	Mass (g)	Orifice (φmm)	Eff. a. (mm ²)
BVLG 20-0608	6	8	50	37	17	17	18.5	28	22	43.5	5	12.5
BVLG 20-0806	8	6	49.5	38		18.5	17	27				11.4
BVLG 60-1012	10	12	62	45	24	21	23.5	37	25	103.5	9	39.7
BVLG 60-1210	12	10	60.5	46.5		23.5	21	35.5				36.1



unit:mm

BVLC 20.60

Elbow

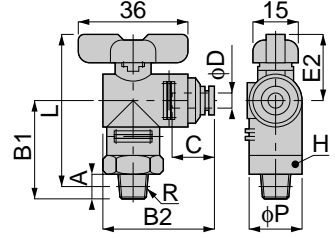

Model	Tube dia. φD	R	A	B1	B2	L	φP	C	E1	E2	H	Mass (g)	Orifice (φmm)	Eff. a. (mm ²)
BVLC 20-0601	6	R1/8	8	32	37	50	17	17	32	22	17	56.5	5	11.7
BVLC 20-0602		R1/4	11	35		51			35			59.5		11.9
BVLC 20-0603		R3/8	12	36		51.5			36			68		
BVLC 20-0801	8	R1/8	8	32	38	50	18.5	18.5	32	25	24	54	6	17.9
BVLC 20-0802		R1/4	11	35		51			35			57.5		18.5
BVLC 20-0803		R3/8	12	36		51.5			36			66		18.7
BVLC 60-1002	10	R1/4	11	43.5	45	62.5	24	21	43.5	25	24	133	8.5	35.8
BVLC 60-1003		R3/8	12	44.5		63			44.5			135.5		36.6
BVLC 60-1004		R1/2	15	47.5		64.5			47.5			152.5		36
BVLC 60-1202	12	R1/4	11	43.5	46.5	62.5	23.5	23.5	43.5	25	24	131	8.5	44.5
BVLC 60-1203		R3/8	12	44.5		63			44.5			133.5		46
BVLC 60-1204		R1/2	15	47.5		64.5			47.5			150.5		46.2



unit:mm

Model	Tube dia. φ D	NPT	A	B1	B2	L	C	E1	E2	H	Weight (g)	Orifice φ mm	Eff.a. mm ²	Cv
BVLC20-1/4 N1U	1/4	1/8	0.31	2.13	1.46	1.10	0.67	1.26	0.87	11/16	57.4	5.0	11.7	0.63
BVLC20-1/4 N2U	1/4	1/4	0.43	2.25	1.46	1.14	0.67	1.38	0.87	11/16	60.7	5.0	11.9	0.64
BVLC20-1/4 N3U	1/4	3/8	0.47	2.29	1.46	1.16	0.67	1.42	0.87	11/16	69.3	5.0	11.9	0.64
BVLC20-5/16 N1U	5/16	1/8	0.31	2.13	1.50	1.10	0.73	1.26	0.87	11/16	55.3	6.0	17.9	0.97
BVLC20-5/16 N2U	5/16	1/4	0.43	2.25	1.50	1.14	0.73	1.38	0.87	11/16	58.8	6.0	18.5	1.00
BVLC20-5/16 N3U	5/16	3/8	0.47	2.29	1.50	1.16	0.73	1.42	0.87	11/16	67.3	6.0	18.7	1.01
BVLC60-3/8 N2U	3/8	1/4	0.43	2.70	1.77	1.56	0.83	1.71	0.98	1.00	136.6	8.5	35.8	1.94
BVLC60-3/8 N3U	3/8	3/8	0.47	2.74	1.77	1.52	0.83	1.75	0.98	1.00	139.5	9.0	36.6	1.98
BVLC60-3/8 N4U	3/8	1/2	0.59	2.85	1.77	1.61	0.83	1.87	0.98	1.00	156.4	9.0	36.0	1.95
BVLC60-1/2 N2U	1/2	1/4	0.43	2.70	1.83	1.56	0.93	1.71	0.98	1.00	132.9	8.5	44.5	2.41
BVLC60-1/2 N3U	1/2	3/8	0.47	2.74	1.83	1.52	0.93	1.75	0.98	1.00	136.6	9.0	46.0	2.49
BVLC60-1/2 N4U	1/2	1/2	0.59	2.85	1.83	1.61	0.93	1.87	0.98	1.00	152.8	9.0	46.2	2.50

unit:inch

BVLM 20.60

Bulkhead Union Elbow

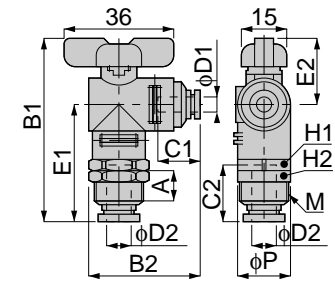

Model	Tube dia. φD1	Tube dia. φD2	M	A	B1	B2	φP	C1	C2	E1	E2	H1	H2	Mass (g)
BVLM 20-0806	6	8	M16×1	11	61	37	17	17	18.5	39	22	19	19	49
BVLM 20-0808	8					38		47						
BVLM 60-1210	10	12	M22×1	17	79	45	24	21	23.5	54	25	24	27	119
BVLM 60-1212	12					46.5		117						

Model	Orifice (φmm)	Eff. a. (mm ²)
BVLM 20-0806	5	11.7
BVLM 20-0808	6	18.6
BVLM 60-1210	9	36.4
BVLM 60-1212	10	45.2



unit:mm

Model	Tube dia. φ D1	Tube dia. φ D2	UNF	F	B1	B2	φ P	C1	C2	E1
BVLM20-5/16 1/4U	1/4	5/16	5/8	0.43	2.40	1.46	0.67	0.67	0.73	1.54
BVLM20-5/16 5/16U	5/16	5/16	5/8	0.43	2.40	1.50	0.67	0.73	0.73	1.54
BVLM60-1/2 3/8U	3/8	1/2	7/8	0.67	3.11	1.77	0.94	0.83	0.93	2.13
BVLM60-1/2 1/2U	1/2	1/2	7/8	0.67	3.11	1.83	0.94	0.93	0.93	2.13

unit:inch

Model	E2	H1	H2	L	Weight (g)	Orifice φ mm	Eff.a. mm ²	Cv
BVLM20-5/16 1/4U	0.87	3/4	3/4	0.16	50.8	5.0	11.7	0.63
BVLM20-5/16 5/16U	0.87	3/4	3/4	0.16	48.8	6.0	18.6	1.00
BVLM60-1/2 3/8U	0.98	1.00	1.00	0.20	117.8	9.0	36.4	1.97
BVLM60-1/2 1/2U	0.98	1.00	1.00	0.20	113.9	10.0	45.2	2.44

unit:inch