

8800 Series Balanced Spool Pressure Control Valves

**90 U.S. gpm (341 L/min) nominal;
Standard 3000 psi (210 bar),
HP Option 5000 psi (350 bar)**

Spool valves provide consistent and accurate control of pressure, regardless of flow variations.

The hydraulically balanced spool is controlled by an integral pilot valve. With a narrow differential between cracking pressure and full flow, these valves are ideal for systems requiring constant actuator force.

Some models are available with integral reverse free-flow check valves.

SPECIFICATIONS

Mounting

8800 Series, Line Connected;
P8800 Series, Subplate Mounted;
F8800 Series, Pattern for Standard
S.A.E. 1-1/2 inch Flange
(Size 10 Only)

Rated Flow

Size 03:

Nominal, 15 U.S. gpm (57 L/min);
Maximum, 20 U.S. gpm (76 L/min)

Size 06:

Nominal, 40 U.S. gpm (151 L/min);
Maximum, 60 U.S. gpm (227 L/min)

Size 10:

Nominal, 90 U.S. gpm (341 L/min);
Maximum, 150 U.S. gpm (568 L/min)

Rated Pressure

Standard:

3000 psi (210 bar)

HP Option:

5000 psi (350 bar); See model
code on page 4 for availability.

Pressure Adjustment

Standard Pressure Range:

100 to 3000 psi (7 to 210 bar)

HP Option:

100 to 5000 psi (7 to 350 bar)

LP Option:

50 to 1000 psi (4 to 70 bar)

LLP Option:

40 to 500 psi (3 to 35 bar)

Pressure is manually set by turning the maximum pressure adjustment (knurled knob or optional handwheel). Turning clockwise increases pressure. The setting is held by a locknut.



*P8800 Series
Subplate Mounted*

*8800 Series
Line Connected*

ELECTRIC VENT OPTION

Size 10 models are available with an electric vent option (normally-open, EVO; or normally-closed, EVC). Pressure is automatically controlled by an integral Dynex D03 valve.

APPLICATION NOTES

Mounting

Orientation: Unrestricted for all models.

Subplate Models: Port o-rings are included. Bolts must be ordered separately; .375-16 U.N.C.–2B Threaded x 4.00 inches (101,6 mm). Recommended torque is 23 lb·ft (31,2 N·m). Size 03 and 06 models require four bolts; Size 10 models require six.

Standard Seals

Fluorocarbon (Viton® or Fluorel®)

Fluid Recommendations

Viscosity:

50 to 1500 SUS (7 to 325 cSt)

Temperature Range:

-20° to +200° F (-29° to +93° C)

Filtration

Use filtration to provide fluid which meets ISO cleanliness level 19/17/14 (ISO Code 4406) or cleaner. Adequate filtration is especially critical for sliding spool valves held in one position for

long periods, subject to system pressure. Silting may cause spool valves to stick and not properly shift. Valves should be cycled periodically.

Pressure Surges

Consistent with standard practice, the system should be protected from pressure surges, which can affect the shifting of any spool valve. In systems with multiple valves, a separate line to tank, or to another low pressure line, is recommended.

PRESSURE DROP (ΔP)

Size	Pressure Range	Flow		Vented ΔP	
		U.S.gpm	L/min	psi	bar
03	Standard	9	34	90	6,2
		20	76	90	6,2
	LP	9	34	30	2,1
		20	76	35	2,4
06	Standard	27	102	90	6,2
		60	227	90	6,2
	LP	27	102	30	2,1
		60	207	75	5,2
10	Standard	55	208	90	6,2
		150	568	90	6,2
	LP	55	208	30	2,1
		150	568	90	6,2

Installation and Dimensions

LINE AND SUBPLATE MODELS

Drawings of the basic configurations show a Size 06 valve as reference. Refer to the appropriate table for variable dimensions for all sizes. See the subplate drawings on page 3, for mounting hole locations.

Optional configurations, including check valves, handwheel and DC solenoids, are shown printed in gray.

Weight (Mass)

Size 03:

- Standard, 7 lb (3,2 kg);
- With Check Valve, 8 lbs (3,6 kg)

Size 06:

- Standard, 12 lb (5,4 kg);
- With Check Valve, 13 lbs (5,9 kg)

Size 10:

- Standard, 30 lb (13,6 kg);
- With Check Valve, 33 lb (15,0 kg)

FLANGE CONNECTED MODELS

For information on flange connected Size 10 models, contact the Dynex sales department.

NOTE: PILOT HEAD SHOWN FOR MODELS 8829 AND 8837. HEAD WILL APPEAR AT OPPOSITE END FOR OTHER MODELS. LOCATIONS ARE ALSO REVERSED FOR EXTERNAL DRAIN AND REMOTE CONTROL/VENT PORTS.

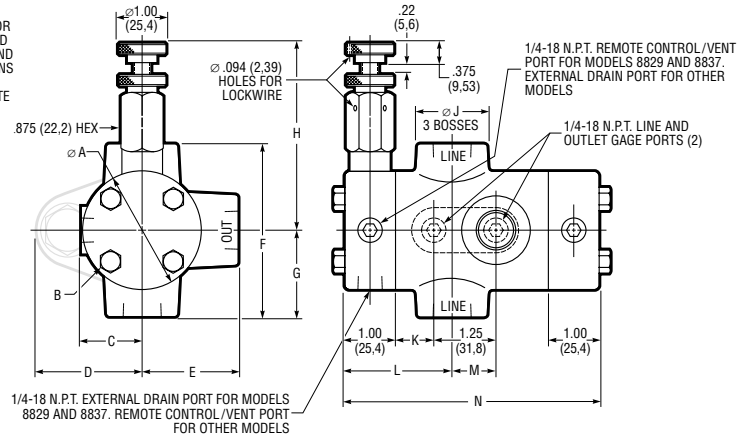

8800 Series, Line Connected

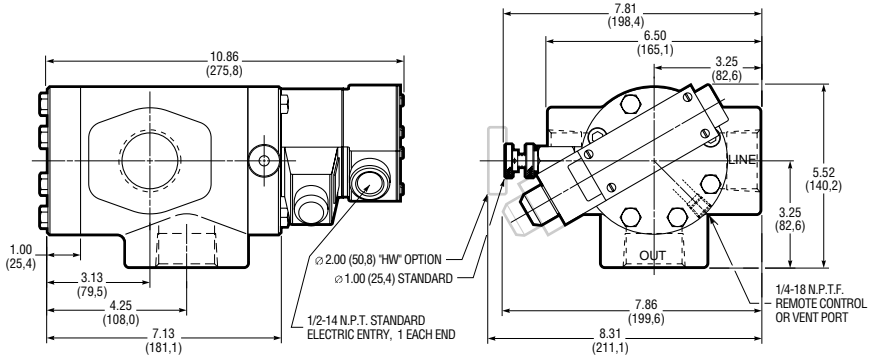

8800 Series, Line Connected, Electric Vent Option (Size 10 Only)

DIMENSIONS – LINE CONNECTED

	Nominal Size		
	03	06	10
A	2.38 (60,5)	3.00 (76,2)	4.50 (114,3)
B	1/4-20	3/8-16	3/8-16
C	1.19 (30,2)	1.50 (38,1)	2.25 (57,2)
D	2.63 (66,8)	2.94 (74,7)	4.56 (115,8)
E	2.00 (50,8)	2.25 (57,2)	3.25 (82,6)
F	3.50 (88,9)	4.12 (104,6)	6.50 (165,1)
G	1.75 (44,4)	2.06 (52,3)	3.25 (82,6)
H	3.69 (93,7)	3.81 (96,8)	4.56 (115,8)
J	1.50 (38,1)	2.25 (57,2)	3.75 (95,2)
K	0.94 (23,9)	1.16 (29,5)	2.94 (74,7)
L	2.16 (54,9)	2.34 (59,4)	3.12 (79,2)
M	0.91 (23,1)	1.06 (26,9)	2.94 (74,7)
N	5.12 (130,0)	5.56 (141,2)	7.12 (180,8)

NOTE: PILOT HEAD SHOWN FOR MODELS 8829 AND 8837. HEAD WILL APPEAR AT OPPOSITE END FOR OTHER MODELS. LOCATIONS ARE ALSO REVERSED FOR EXTERNAL DRAIN AND REMOTE CONTROL/VENT PORTS

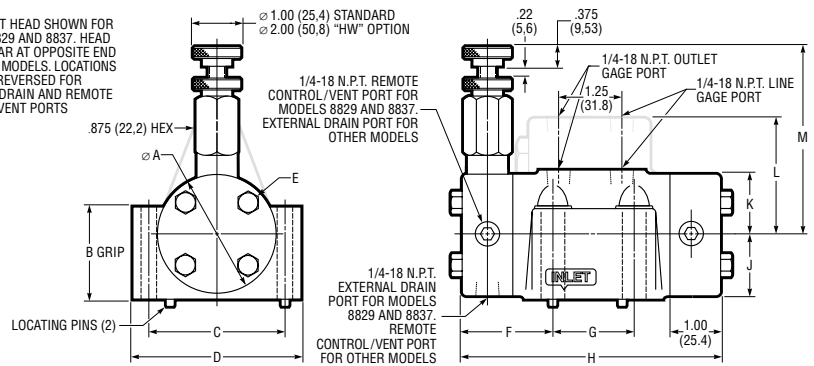

P8800 Series, Subplate Mounted

DIMENSIONS – SUBPLATE

	Nominal Size		
	03	06	10
A	2.38 (60,5)	3.00 (76,2)	4.50 (114,3)
B	1.75 (44,4)	2.00 (50,8)	3.38 (85,9)
C	2.625 (66,68)	3.125 (79,38)	3.812 (96,82)
D	3.38 (85,9)	3.88 (98,6)	4.62 (117,3)
E	1/4-20	3/8-16	3/8-16
F	1.72 (43,7)	1.59 (40,4)	1.91 (48,5)
G	1.688 (42,88)	2.375 (60,32)	3.312 (84,12)
H	5.12 (130,0)	5.62 (142,7)	7.12 (180,8)
J	1.25 (31,8)	1.62 (41,1)	2.31 (58,7)
K	1.19 (30,2)	1.50 (38,1)	2.25 (57,2)
L	2.25 (57,2)	2.50 (63,5)	4.56 (115,8)
M	3.69 (93,7)	3.81 (96,8)	4.56 (115,8)

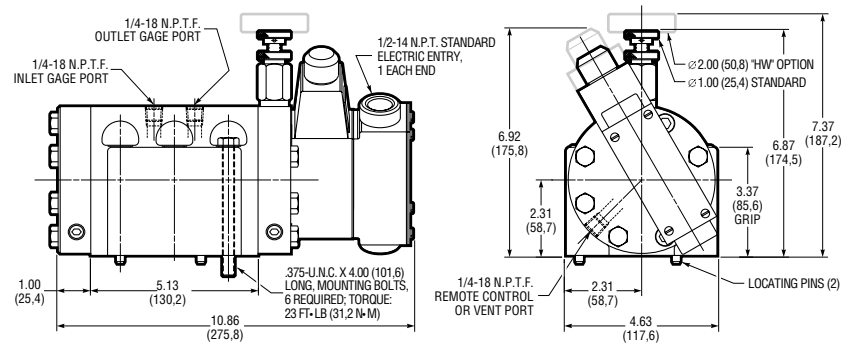

P8800 Series, Subplate Mounted, Electric Vent Option (Size 10 Only)

Balanced Spool Valve Functions

RELIEF VALVES

Relief valves are normally closed controls that regulate pressure to a desired preset maximum.

Their most common use is to protect against excessive pressure. The valve is adjusted so it opens at a pressure slightly higher than the load requirement. When reached, the valve diverts excess pump output flow to tank.

Pressure can be controlled by a remote pressure source, such as a Dynex 8820 Series panel mounted valve.

Relief valves also provide an unloading function, venting pump output during idle portions of a machine cycle. Venting can be controlled by a two-position directional control valve (a Dynex D03 valve, for example) in the circuit.

REDUCING VALVES

Reducing valves are normally open controls that provide flow at a regulated pressure, typically supplied to a branch circuit in a system.

For example, a pump might be supplying flow at 3000 psi (210 bar). The valve can tap into this circuit, providing a pressure regulated secondary flow to move a load limited to only 500 psi (35 bar).

The valve is set so it closes when pressure in the branch circuit reaches a level slightly higher than 500 psi (35 bar). The valve then regulates flow to maintain the 500 psi (35 bar) pressure in the branch circuit.

The valves can be controlled by a remote pressure source, such as a Dynex 8820 Series panel mounted valve. If the branch requires rapid de-pressurization, a two-position directional control valve (a Dynex D03 valve, for example) can provide solenoid operated venting.

UNLOADING VALVES

Unloading valves are normally closed controls that divert pump output directly to tank in response to an external pressure signal.

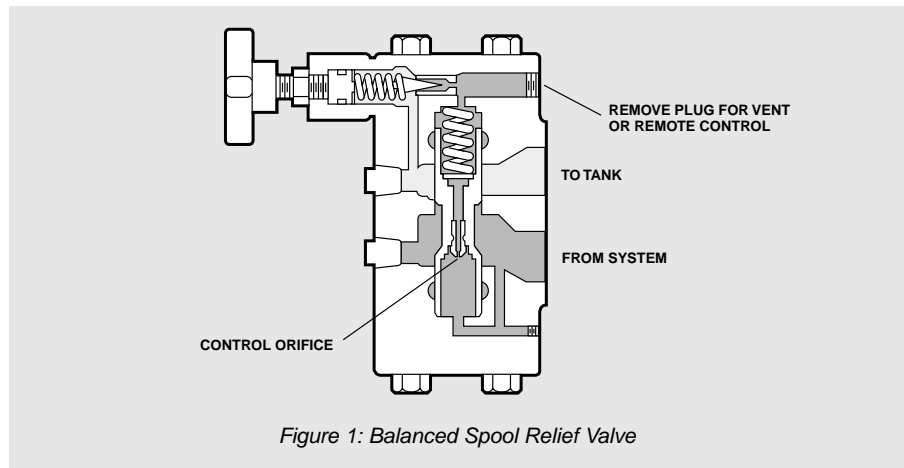

Figure 1: Balanced Spool Relief Valve

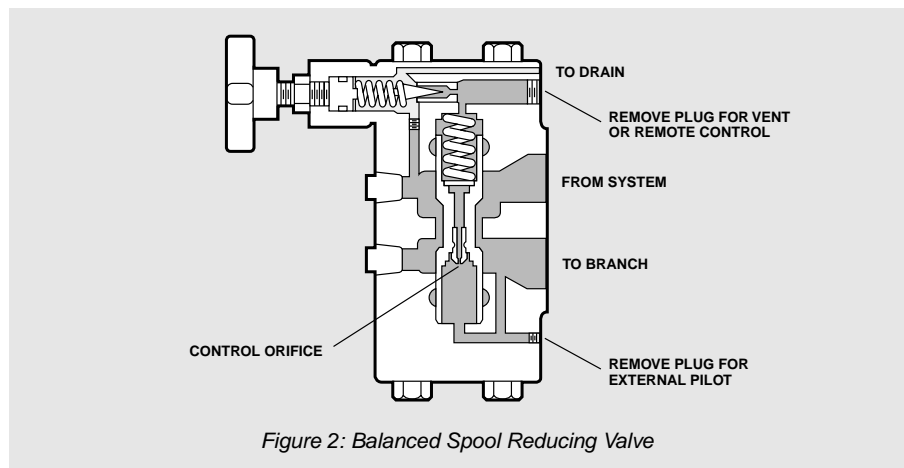

Figure 2: Balanced Spool Reducing Valve

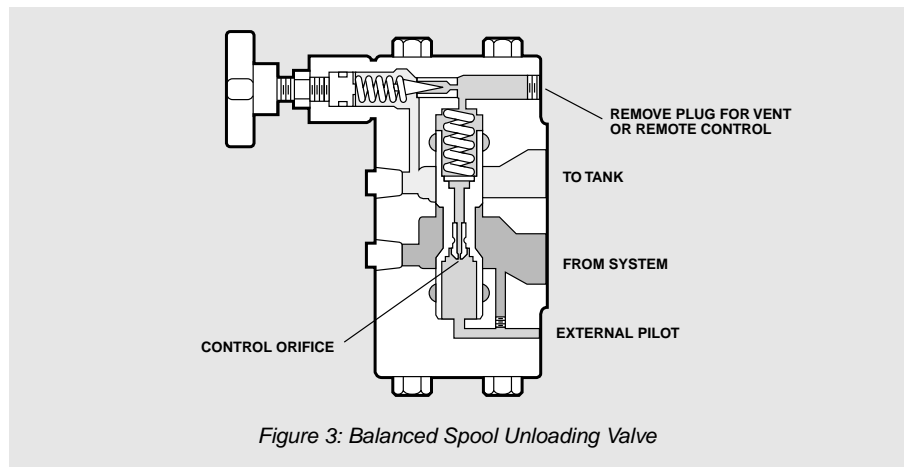

Figure 3: Balanced Spool Unloading Valve

These valves are commonly used in “Hi-Lo” circuits. Combined two-pump output is supplied to the system until the load reaches the pre-set pressure setting of the unloading valve. Pilot pressure then opens the valve and delivery from the high

output pump is unloaded with minimum pressure drop.

Pressure can be controlled by a remote pressure source, such as a Dynex 8820 Series panel mounted valve.

COUNTERBALANCE VALVES

Counterbalance valves control and prevent runaway and overhauling loads caused by inertia. These models should not be used for gravity applications.

The normally closed valve is connected downstream of the cylinder, blocking normal return to tank. This creates back pressure on the load end, preventing runaway of the load.

The valve is pre-set to a pressure slightly higher than the pressure produced by the inertia of the load. Once the back pressure on the load end reaches this level, the valve opens and flow to tank is unrestricted.

Subsequently, if the cylinder begins to runaway, back pressure falls off and the valve closes. In this manner, the valve assures that load movement is controlled by pump flow alone.

The valve can be externally piloted or remotely controlled. Since most applications require reverse free flow, an integral check valve is provided.

SEQUENCE VALVES

Sequence valves are normally closed controls that provide flow to a branch circuit at a preset pressure. This allows sequential performance of one or more functions in a system.

Internally piloted models maintain the set pressure in the primary circuit. See *Figure 5*.

Externally piloted models allow flow to the secondary circuit when actuated by pressure from a remote pilot source, such as a Dynex 8820 Series panel mounted valve. See *Figure 6*.

The sequence valve opens fully when pilot pressure reaches 100 psi (7 bar) higher than the valve setting. Pressure in the primary circuit will then drop to the load pressure of the secondary circuit.

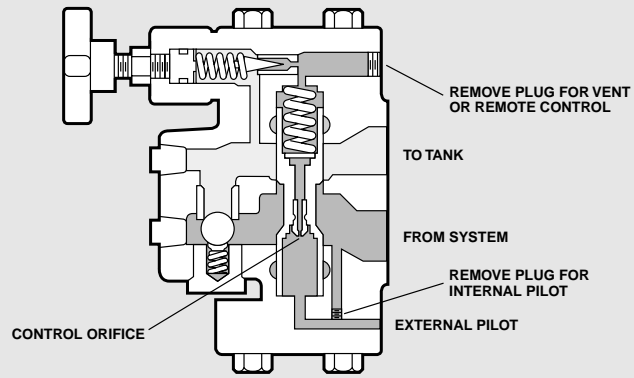

Figure 4: Counterbalance Valve with Integral Check Valve

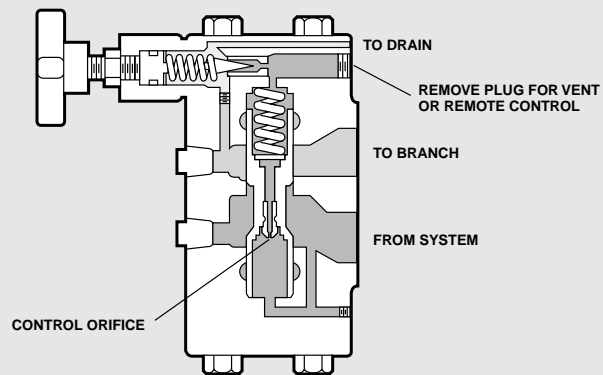

Figure 5: Internally Piloted Sequence Valve

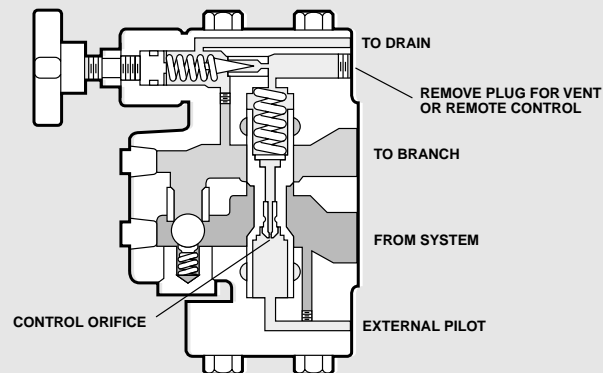

Figure 6: Externally Piloted Sequence Valve with Integral Check Valve

Subplates and Mounting Bolt Kits

P8800 SUBPLATE MODELS

P8 (03 Size), P9 (06 Size) and P10 (10 Size) subplates are available for mounting under P8800 models.

Valve mounting bolts are supplied when ordering subplates. When ordering valves and subplates together, valves are not mounted on subplates.

The gray area in the drawings indicates the minimum mounting surface required for mounting these valves when a subplate is not used.

Mounting Bolt Kits

Mounting bolts are not included when ordering valve alone. The table below includes available mounting bolt kits.

Item: Part Number	Description
Subplate: P8-1/2	Bottom Ports, 1/2-14 N.P.T.F.
Bolt Kit: P8-BK	Four .375-16 U.N.C.-2B Threaded x 2.25 inches (57,2 mm)
Subplate: P9-1	Bottom Ports, 1-11/2 N.P.T.F.
Bolt Kit: P9-BK	Four .375-16 U.N.C.-2B Threaded x 2.50 inches (63,5 mm)
Subplate: P10-1/2	Bottom Ports, 1-1/2-11-1/2 N.P.T.F.
Bolt Kit: P10-BK	Six .375-16 U.N.C.-2B Threaded x 4.00 inches (101,6 mm)
Flanges: ^①	
85-6055	1-1/2 inch N.P.T.F.
85-6105	1-1/2 inch Socket Weld

① For details on flange connected Size 10 models, contact the Dynex sales department.

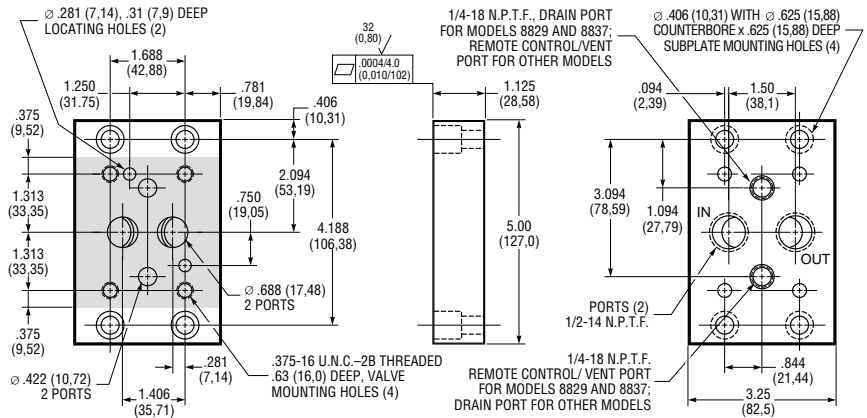

Subplate P8-1/2

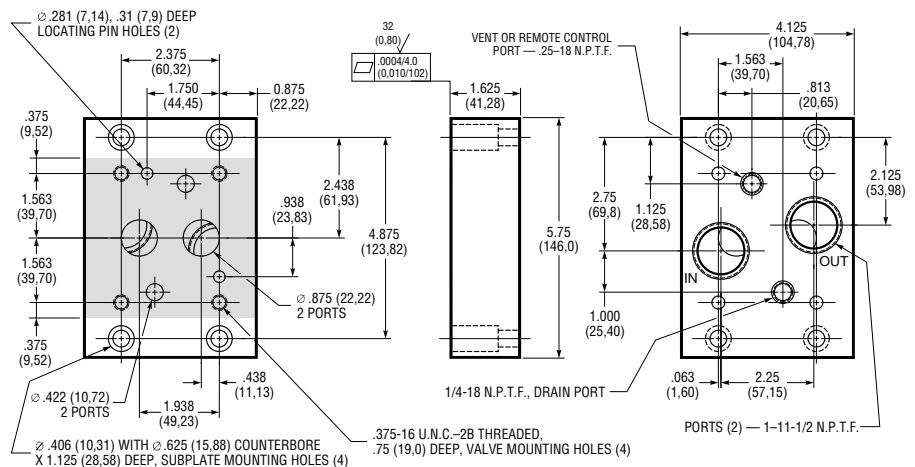

Subplate P9-1

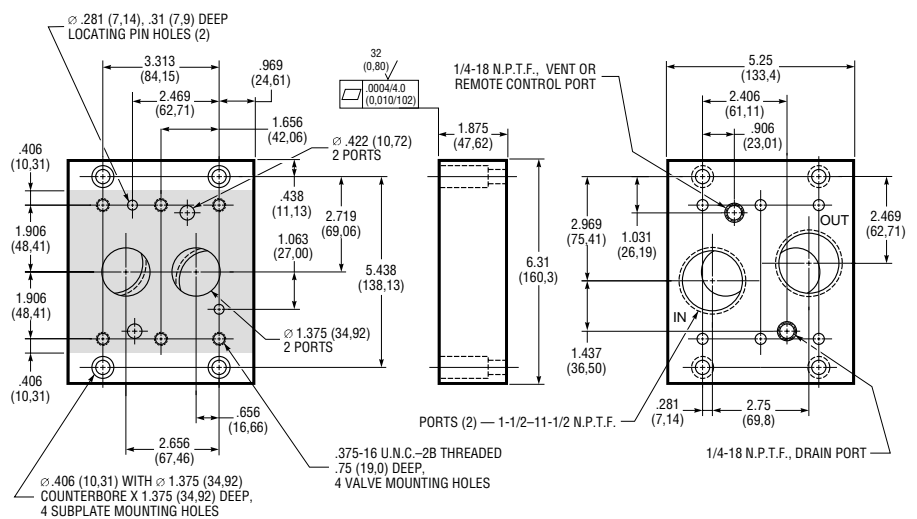

Subplate P10-1/2

P

88 37

— 10-1-1/2

EVO

— 24/DF — 2

5

Valve Mounting	
No Code	Line Connected
P	Subplate Mounted
F	Flange Connected ^①

^① Size 10 only; For complete information, contact the Dynex sales department.

Valve Type	
88	Pressure Control

Nominal Size	
03	1/2 Inch N.P.T. Ports
06	1 Inch N.P.T. Ports
10	1-1/2 Inch N.P.T. Ports; or 1-1/2 Inch Flange

Modification Number

Design Number

Options	
No Code	Standard, adjustable 100 to 3000 psi (7 to 210 bar)
LP	Adjustable 50 psi to 1000 psi (4 to 70 bar)
LLP	Adjustable 40 psi to 500 psi (3 to 35 bar)
HP	Adjustable 100 psi to 5000 psi (7 to 350 bar)
HW	Handwheel ^①
CR	Corrosion Resistant ^①
EVO	Electric Vent, Normally Open ^②
EVC	Electric Vent, Normally Closed ^②

^① With EVO or EVC option, available in AC only.
^② Available on Size 10 valves only.

HP Option Availability				
Valve Type	Size	Mounting		
		Line	Flange	Subplate
With Check Valve	03	Yes	-	No
	06	Yes	-	No
	10	No	No	No
Without Check Valve	03	No	-	Yes
	06	Yes	-	Yes
	10	Yes	Yes	Yes

Electric Vent Options (Size 10 Only)

- STANDARD SOLENOIDS:^①
- 24/DF — Dual Frequency, 24/60, 24/50
 - 115/DF — Dual Frequency, 115/60, 110/50
 - 230/DF — Dual Frequency, 230/60, 220/50
 - 460/DF — Dual Frequency, 460/60, 440/50
 - 12VDC — Direct Current, 12 Volts
 - 24VDC — Direct Current, 24 Volts
 - 110/50 EPW — Explosion Proof Solenoids
 - 115/60 EPW — Explosion Proof Solenoids
 - 220/50 EPW — Explosion Proof Solenoids

- PLUG-IN TERMINAL SOLENOIDS:^②
- 115/HAC — Dual Frequency, 115/60, 110/50
 - 230/HAC — Dual Frequency, 230/60, 220/50
 - 12/HDC — Direct Current, 12 Volts
 - 24/HDC — Direct Current, 24 Volts

- SOLENOID OPTIONS:
- C — CSA and UL Recognized Coils (Etched with Symbol)^③
 - M — Hand Actuated Manual Override^④
 - T — Terminal Strip^⑤
 - CG — Cable Grip, for 3/8 to 7/16 inch (9,5 to 11,1 mm) O.D. machine tool cable^③
 - SL — Solenoid Lights (Available 115/DF AC Only)^③
 - HPT — High Pressure Tank Port^④
 - 2300 psi (160 bar) maximum AC models
 - 3000 psi (210 bar) maximum DC models
 - BH3A — 3-pin Connector (NFPA standard T3.539-1980), for single solenoid models, on port "A" end of valve^③
 - BH3B — 3-pin Connector, for single solenoid models, on port "B" end of valve^③
 - BH5A — 5-pin Connector for single or double solenoid models on port "A" end of valve^③
 - BH5B — 5-pin Connector for single or double solenoid models on port "B" end of valve^③

^① For other voltages, consult the Dynex sales department.
^② Fits DIN Connector Standard 43650 (Hirschmann GDM 209).
^③ Available with 115/DF solenoids only. For other voltages, consult the Dynex sales department.
^④ Option not available with "EPW" solenoid models.
^⑤ Options not available with "EPW" nor "Plug-In Terminal" solenoid models.

Valve Function

	With Check Valve		Without Check Valve		
	Subplate	Line	Subplate	Line	
13 — Counterbalance ^① XPID			21 — Relief IPID		
29 — Reducing IPXD			23 — Sequence IPXD		
31 — Counterbalance ^① IPID			25 — Sequence XPXD		
33 — Sequence IPXD			27 — Unloading XPID		
35 — Sequence XPXD			37 — Reducing IPXD		

^① These models should not be used for gravity applications.

For more information
 visit our web site:
www.fullyeartrading.com