

## Checkball Piston Pumps For Water-Based Fluids

**PF1300 SERIES**  
**0.31 to 1.42 gpm (1,18 to 5,37 L/min) at 1800 rpm**  
**8000 to 10 000 psi (560 to 700 bar)**

Fixed displacement checkball pumps are compatible with a variety of water-based and other low-lubricity fluids. Bi-directional shaft rotation provides constant direction of output flow regardless of drive shaft rotation.

### MAINTENANCE-FREE DESIGN

The single-fluid checkball design uses the pumped fluid for internal bearing lubrication. This eliminates the potential for fluid cross-contamination, possible in other designs with isolated lubrication. It also avoids the cost of a lubrication circuit.

### RELIABLE HIGH PRESSURE

Individual piston check valves provide long service life and greater volumetric efficiency, especially at high pressures and with low-lubricity fluids.

The check valves take the place of a valveplate in other pump designs. With no rotating sealing surface, checkball pumps are resistant to wearing and scoring.

### TYPICAL APPLICATIONS

These pumps are ideal for use in wellhead safety control systems and other subsea applications, providing long life operating at high pressures with water-based fluids.

They are also used on hydroform presses, and other applications requiring environmentally-friendly or fire-resistant fluids.

### PUMP SELECTION

The table shows specifications for standard pressure models, and for high pressure "H" option models for maximum pressures to 10 000 psi (700 bar). The "H" option requires high pressure coned and threaded or B.S.P. outlet ports.

Refer to "Typical Model Code" to specify shaft, seal and outlet port options.



### Specifications

Pump Models	Output Flow at 1500 rpm <sup>①</sup>		Output Flow at 1800 rpm <sup>①</sup>		Maximum Pressure		Rated Speed rpm
	U.S. gpm	L/min	U.S. gpm	L/min	psi	bar	
PF1301-10	0.26	0,98	0.31	1,18	8000	560	1800
PF1303-10	0.36	1,35	0.43	1,63	8000	560	1800
PF1305-10	0.46	1,73	0.55	2,08	8000	560	1800
PF1308-10	0.60	2,30	0.73	2,76	8000	560	1800
PF1315-10	0.76	2,87	0.91	3,45	8000	560	1800
PF1318-10	1.01	3,82	1.21	4,58	8000	560	1800
PF1320-10	1.18	4,47	1.42	5,37	8000	560	1800
PF1301H-10	0.25	0,95	0.30	1,14	10 000	700	1800
PF1303H-10	0.35	1,31	0.42	1,58	10 000	700	1800
PF1305H-10	0.44	1,70	0.54	2,03	10 000	700	1800
PF1308H-10	0.60	2,26	0.72	2,73	9000	630	1800
PF1315H-10	0.74	2,80	0.89	3,37	10 000	700	1800
PF1318H-10	1.00	3,78	1.20	4,54	9000	630	1800

<sup>①</sup> Output flow based on typical performance using 33 SUS (1,9 cSt) water glycol fluid at maximum pressure with flooded inlet.

## INSTALLATION AND OPERATING

Refer to separate Bulletin PSI.CB for general installation and operating recommendations.

All dimensions are shown in inches (millimeters in parentheses) and are nominal.

Note that Models PF1301, PF1303, PF1305 and PF1308 have three pistons. Other models have five pistons.

### Mounting

S.A.E. A 2-bolt pattern with 0.25 inch (6,4 mm) pilot engagement.

### Shaft

Standard keyed shaft, 0.875 inch (22,20 mm) diameter;

Optional spline shaft, 0.873/0.872 inch diameter standard S.A.E. 13 tooth, 16/32 D.P. 30° involute spline.

### Outlet Port Options

Standard pressure models are available with S.A.E. ports. High pressure "H" option models require the use of outlet port option "A" (Autoclave Medium Pressure, Butech M/P or equivalent fittings), or outlet port option "B" (British Standard Pipe fittings).

### Inlet Conditions

Pumps using water-based fluids require a flooded inlet up to 1800 rpm rated speed. Higher viscosity fluids may require pressurized inlet conditions.

Contact the sales department for applications requiring continuous duty operation at speeds higher or lower than shown in the "Typical Performance Curves".

## Hydraulic Fluid Viscosity Guidelines<sup>①</sup>

Operating					
Minimum		Maximum		Start-up	
SUS	cSt	SUS	cSt	SUS	cSt
31	1,3	927	200	927	200

① If fluid conditions fall outside of the range shown, contact the sales department.

### Orientation/Drive

Shaft horizontal with inlet vertically up is preferred. Vertical shaft mounting is possible, but requires connecting a line to the bleed port to remove air from the pump housing.

### Seal Options

Standard seals are Buna-N (Nitrile) with Polyurethane (Disogrin®) o-rings in the cover. Options include Fluorocarbon (Viton® or Fluorel®) with Polyurethane (Disogrin®) o-rings in the cover, all Fluorocarbon with high pressure shaft seal, or EPR seals for use with some phosphate ester fluids. Refer to "Typical Model Code".

### Minimum Filtration Levels

Pump inlet: 150 μ nominal;  
Pressure or return line: 25 μ nominal.

While finer filtration levels than these are desirable and will result in longer component life, restricting flow to the pump inlet should be avoided. Minimum recommended inlet conditions must be maintained.

### Weight (Mass)

36 lb (16 kg)

## FLUID RECOMMENDATIONS

### Special Fluid Operation

Because of the wide range of water-based fluid characteristics, contact the sales department for a review of the non-petroleum based fluid required for the application.

### Viscosity Specifications

Using fluid with the correct viscosity range is critical to achieving long component life.

Fluid conditions outside the ranges shown in the table may result in reduced pump output, requiring pressurized inlet conditions. For more information, contact the sales department.

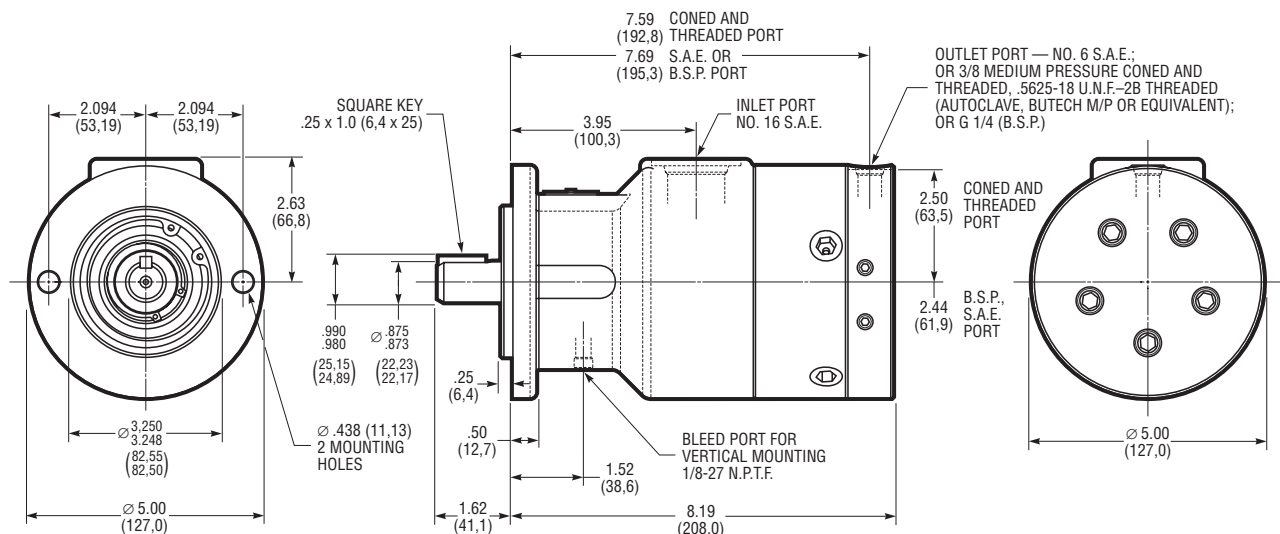

# Typical Performance Curves

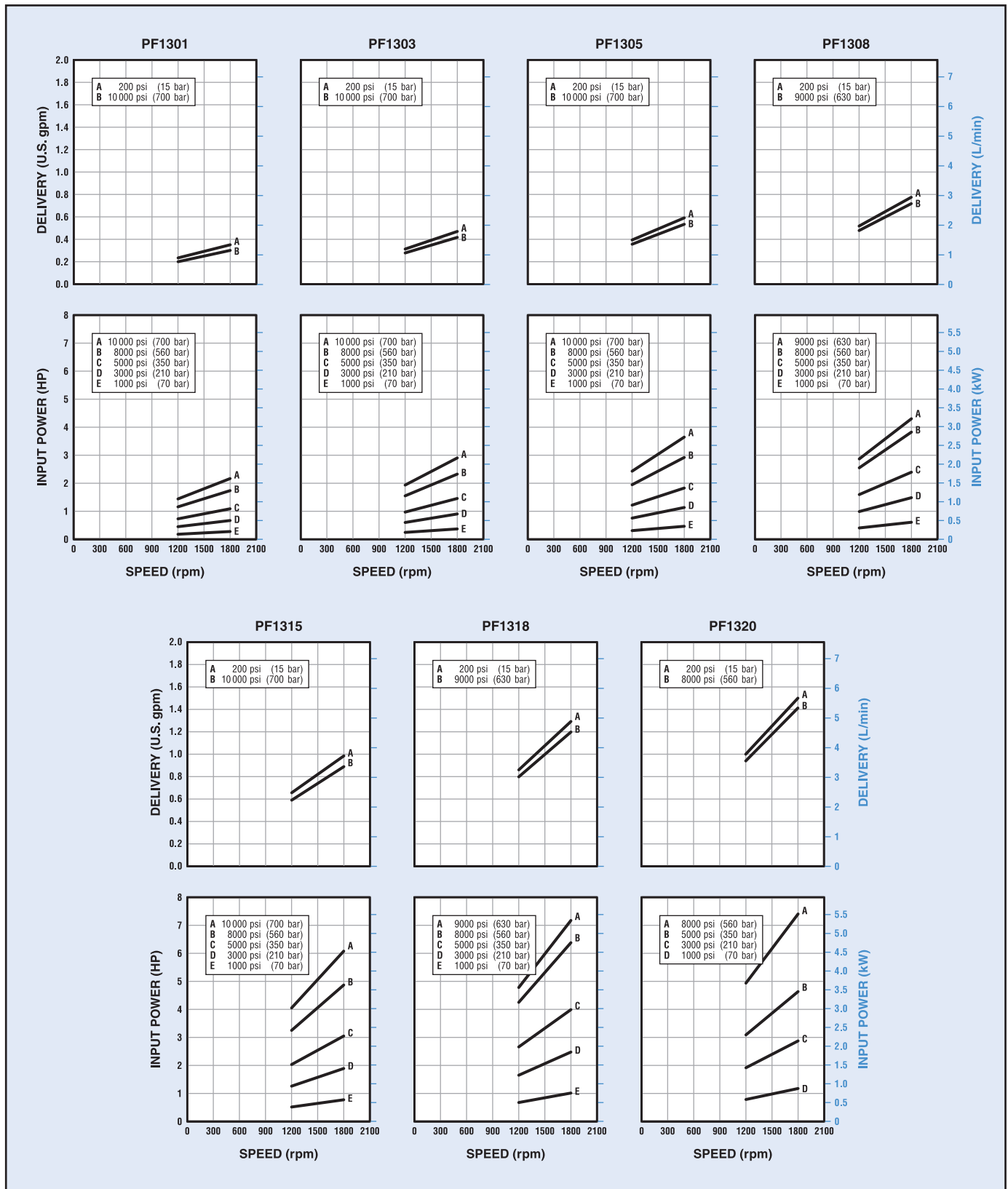

Typical performance curves are based on 33 SUS (1,9 cSt) water glycol fluid with flooded inlet. Contact the sales department for applications requiring continuous duty operation at speeds higher or lower than shown.

# TYPICAL MODEL CODE

PF13

01

H - S D

A

-

1

0

Pump Type	
PF13	Fixed Displacement Checkball Pump

Output Flow (At 1800 rpm, at maximum pressure) <sup>①</sup>	
01	Standard: 0.31 (1,18 L/min) "H" Option: 0.30 gpm (1,14 L/min)
03	Standard: 0.43 (1,63 L/min) "H" Option: 0.42 gpm (1,58 L/min)
05	Standard: 0.55 (2,08 L/min) "H" Option: 0.54 gpm (2,03 L/min)
08	Standard: 0.73 (2,76 L/min) "H" Option: 0.72 gpm (2,73 L/min)
15	Standard: 0.91 (3,45 L/min) "H" Option: 0.89 gpm (3,37 L/min)
18	Standard: 1.21 (4,58 L/min) "H" Option: 1.20 gpm (4,54 L/min)
20	Standard: 1.42 (5,37 L/min)

① Output flows based on typical performance at maximum pressure. Refer to performance curves for flows at lower pressure.

② Models PF1301, PF1303, PF1305 and PF1308 have three pistons. Other models have five pistons.

Operating Pressure	
No Code	Standard Pressure
H	High Pressure <sup>①</sup>

① Requires "A" or "B" port option.

Ports	
No Code	Inlet No. 16 S.A.E.; Outlet No. 6 S.A.E. <sup>①</sup>
A	Inlet No. 16 S.A.E.; Outlet 3/8 Medium Pressure Coned and Threaded, 0.5625-18 U.N.F.-2B Threaded <sup>②</sup>
B	Inlet No. 16 S.A.E.; Outlet G 1/4 (B.S.P.) <sup>③</sup>

① Not recommended for operation above 8000 psi (560 bar). Contact the fitting manufacturer for the pressure rating of the fitting.

② High pressure port uses Autoclave Medium Pressure, Butech M/P or equivalent fitting.

③ Outlet port uses British Standard Pipe fitting. Not recommended for operation above 10 000 psi (700 bar).

Design Number

Modification Number

Seals	
D	Standard: Buna-N (Nitrile) with Polyurethane (Disogrin <sup>®</sup> ) o-rings in the cover
XD	Fluorocarbon (Viton <sup>®</sup> or Fluorel <sup>®</sup> ) with Polyurethane (Disogrin <sup>®</sup> ) o-rings in the cover and High Pressure Shaft Seal
XE	All EPR with High Pressure Shaft Seal <sup>①</sup>
XV	All Fluorocarbon (Viton <sup>®</sup> or Fluorel <sup>®</sup> ) with High Pressure Shaft Seal

① Contact the sales department for recommended operating conditions with EPR seals.

Drive Shaft	
No Code	Keyed, .875 inch (22,23 mm) diameter
S	S.A.E. Spline, .875 inch (22,23 mm) diameter

Specifications shown were in effect when printed. Since errors or omissions are possible, contact your sales representative or the sales department for the most current specifications before ordering. Dynex reserves the right to discontinue products or change designs at any time without incurring any obligation.

Download Dynex Product Specifications!

[www.fullyeartrading.com](http://www.fullyeartrading.com)

