

PF1000 SERIES



PUMP DESCRIPTION

Fixed displacement checkball pumps, with bi-directional shaft rotation, provide constant direction of output flow regardless of the direction of drive shaft rotation.

Mounting

S.A.E. A 2-bolt pattern with 0.25 inch (6,4 mm) pilot engagement.

Shaft Options

Standard keyed shaft, 0.875 inch (22.20 mm) diameter;

Optional spline shaft, 0.873/0.872 inch diameter standard S.A.E. 13 tooth, 16/32 D.P. 30° involute spline.

Outlet Port Options

Standard pressure models have S.A.E. ports. The high pressure "H" option requires the use of outlet port option "A" (Autoclave Medium Pressure, Butech M/P or equivalent fittings), or outlet port option "B" (British Standard Pipe fittings).

Inlet Conditions

Pumps may require pressurized inlet conditions at higher speeds. Failure to meet minimum inlet requirements will result in slight flow reduction. Refer to the table.

Seal Options

Standard seals are Buna-N (Nitrile). Options include Fluorocarbon (Viton® or Fluorel®), or EPR for use with some phosphate ester fluids.

Weight (Mass)

30 lb (14 kg)

Specifications

Pump Models	Output Flow at 1500 rpm ^①		Output Flow at 1800 rpm ^①		Rated Pressure		Maximum Intermittent Pressure		Rated Speed rpm ^②	Maximum Speed rpm ^②
	U.S. gpm	L/min	U.S. gpm	L/min	psi	bar	psi	bar		
PF1002-10	1.2	4,7	1.5	5,7	6000	420	8000	560	1800	3600
PF1003-10	1.7	6,6	2.1	7,9	6000	420	8000	560	1800	3600
PF1004-10	2.1	8,2	2.6	9,8	6000	420	8000	560	1800	3600
PF1005-10	2.9	11,0	3.5	13,2	6000	420	8000	560	1800	2800
PF1006-10	3.4	12,9	4.1	15,5	6000	420	8000	560	1800	2800
PF1007-10	4.1	15,7	5.0	18,9	4000	280	6000	420	1800	2800
PF1008-10	4.9	18,6	5.9	22,3	4000	280	6000	420	1800	2800
PF1002H-10	1.2	4,7	1.5	5,7	6000	420	10 000	700	1800	3600
PF1003H-10	1.7	6,6	2.1	7,9	6000	420	10 000	700	1800	3600
PF1004H-10	2.1	8,2	2.6	9,8	6000	420	10 000	700	1800	3600
PF1005H-10	2.9	11,0	3.5	13,2	6000	420	10 000	700	1800	2800
PF1006H-10	3.4	12,9	4.1	15,5	6000	420	10 000	700	1800	2800

^① Output flow based on typical performance at rated pressure with pressurized inlet where required, as shown in the table below.

^② Contact the sales department for applications requiring operation above rated speed. High speed operation may require a pressurized inlet. Refer to "Inlet Conditions".

Minimum Inlet Pressure^①

Pump Models	Operating Speed							
	1800 rpm		2200 rpm		2800 rpm		3600 rpm	
	psi	bar	psi	bar	psi	bar	psi	bar
PF1002	0	0	0	0	0	0	5	0,4
PF1003 and PF1004	0	0	0	0	5	0,4	10 ^②	0,7 ^②
PF1005, PF1006, PF1007 and PF1008	0	0	5	0,4	10 ^②	0,7 ^②	–	–

^① Values shown are based on fluid viscosity of 100 SUS (20 cSt).

^② Inlet pressures higher than 10 psig (0,7 bar) require a high-pressure shaft seal. Refer to "Typical Model Code" on page 4 for seal options.

PUMP SELECTION

The table shows specifications for standard pressure and high pressure "H" option models.

Ordering a PF1000 Series, 10 Design, pump requires a complete model code specifying shaft, seal and outlet port options. Refer to "Typical Model Code" on page 4.

Maximum Pressure

Checkball pumps are especially suited for applications susceptible to excessive pressure spikes.

The intermittent pressures listed are the maximum pressures a pump can sustain for occasional, short periods of operation without appreciably reducing life expectancy.

Fluid Guidelines

See page 5 for "Fluid Recommendations".

Some pump models may require reduced operating pressures when using low-lubricity fluids.

Because of the wide range of fluid characteristics, contact the sales department for a review of any application using non-petroleum based fluids.

Split-Flow® Provides Multiple Outlets

PF1000 models with split-flow covers efficiently supply flows for multiple function circuits. Piston outputs are grouped together in the cover, with various piston flow splits available in this four-piston pump. Refer to "Typical Model Code" on page 4 and contact the sales department for availability.

PF1000 SERIES

Typical Performance Curves

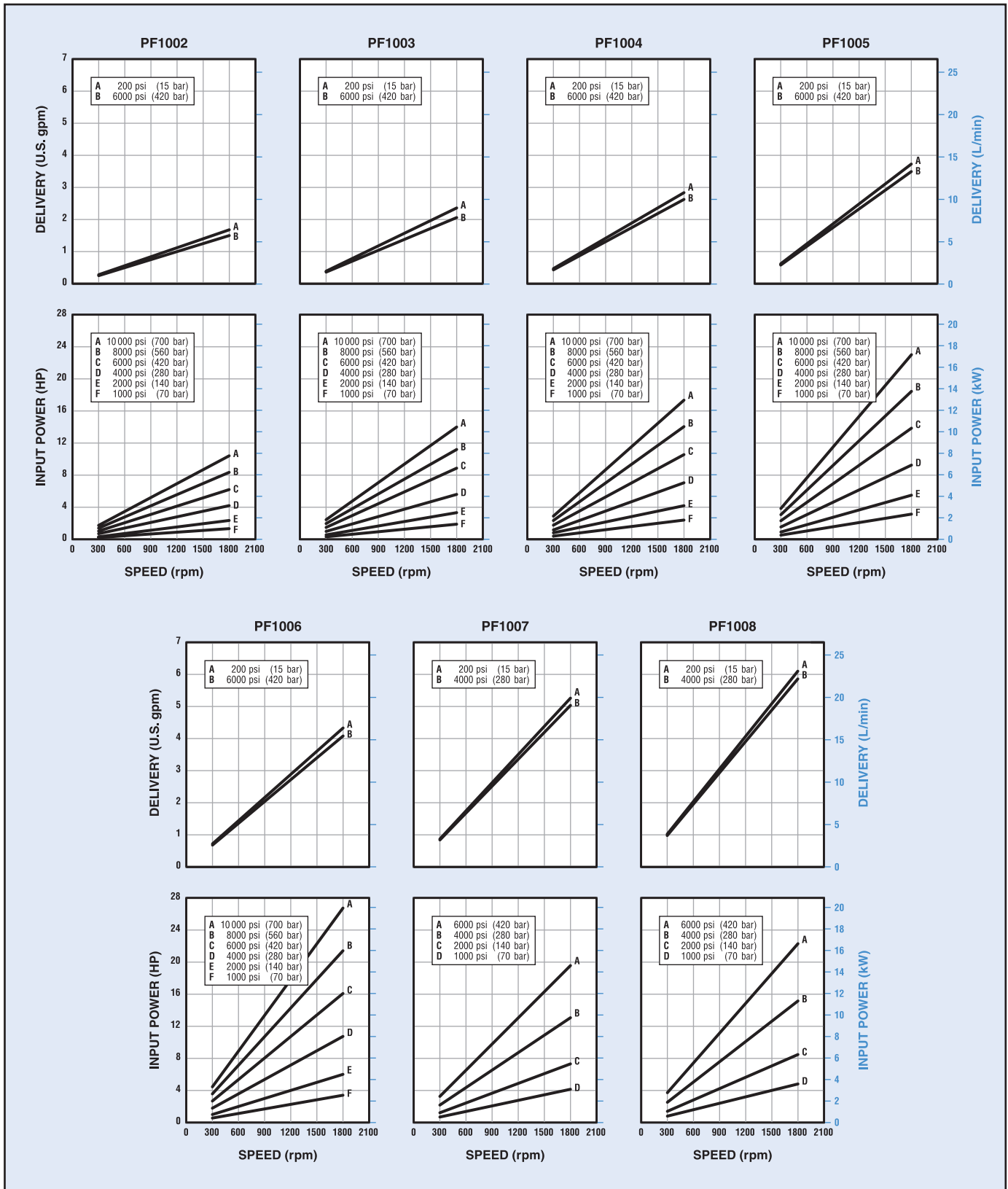

Typical performance curves are based on 100 SUS (20 cSt) mineral oil with pressurized inlet where required. Refer to the "Minimum Inlet Pressure" table on page 2.

PF1000 SERIES

INSTALLATION

All dimensions are shown in inches (millimeters in parentheses) and are nominal. See page 6 for spline shaft data. Refer to Bulletin PSI.CB for general installation and operating recommendations.

The drawing shows dimensions common to all PF1000 models. Note that the dimension for the outlet port varies as shown, dependent on the type of port. Refer to

"Outlet Port Configurations" on page 6 and "Typical Model Code" below to specify port.

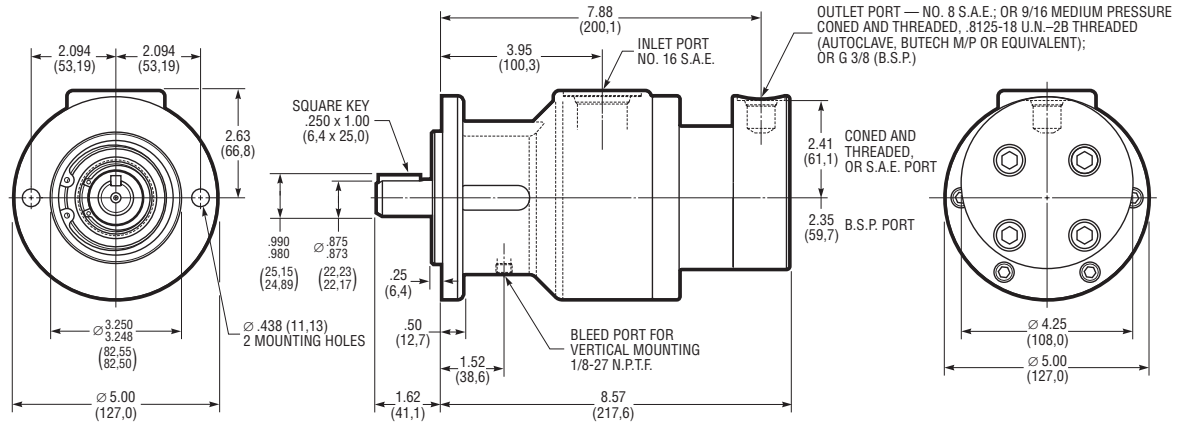

TYPICAL MODEL CODE

PF10 02 H - S XV A - 22 - 1 0

Pump Type	
PF10	Fixed Displacement Checkball Pump

Output Flow (At 1800 rpm, at rated pressure) ^①	
02	1.5 gpm (5,7 L/min)
03	2.1 gpm (7,9 L/min)
04	2.6 gpm (9,8 L/min)
05	3.5 gpm (13,2 L/min)
06	4.1 gpm (15,5 L/min)
07	5.0 gpm (18,9 L/min) ^②
08	5.9 gpm (22,3 L/min) ^②

① Output flows based on typical performance at rated pressure. Refer to performance curves for flows at lower pressures.
② Not available with high pressure "H" option.

Operating Pressure	
No Code	Standard Pressure
H	High Pressure ^①

① Requires "A" or "B" port option.

Drive Shaft	
No Code	Keyed, 0.875 inch (22,20 mm) diameter
S	S.A.E. Spline, .875 inch (22,20 mm)

Ports	
No Code	Inlet No. 16 S.A.E.; Outlet No. 8 S.A.E. ^①
A	Inlet No. 16 S.A.E.; Outlet 9/16 Medium Pressure Coned and Threaded, 0.8125-16 U.N.-2B Threaded ^②
B	Inlet No. 16 S.A.E.; Outlet G 3/8 (B.S.P.) ^③

① Not recommended for operation above 8000 psi (560 bar). Contact the fitting manufacturer for the pressure rating of the fitting.
② High pressure port uses Autoclave Medium Pressure, Butech M/P or equivalent fitting.
③ Outlet port uses British Standard Pipe fitting. Not recommended for operation above 10 000 psi (700 bar).

Split-Flow [®] Options (4 Piston Pump) ^①	
No Code	Full flow from single outlet
Split-Flow [®] Cover Models:	
22	Two-pistons output + Two-pistons output
31	Three-pistons output + One-piston output
4X	Four ports, each with one-piston output
2	Two pistons output + Two inactive pistons

① For outlet port sizes, locations and pump cover dimensions, contact the sales department.

Seals	
No Code	All Buna-N (Nitrile) ^①
XE	All EPR with High Pressure Shaft Seal ^①
XV	All Fluorocarbon (Viton [®] or Fluorel [®]) with High Pressure Shaft Seal

① Not available with High Pressure "H" option. Contact the sales department for recommended operating conditions.

Design Number

Modification Number

FLUID RECOMMENDATIONS

Mineral Oil

A high-grade premium petroleum-based fluid should be used to assure long component and system life. The fluid should have a combination of anti-wear, demulsibility, rust protection, oxidation-resistant and foam-resistant properties.

Special Fluids

Various pump models are available for use with water-based fluids, diesel calibration fluids, phosphate ester fluids, machining coolant, brake fluid, various military fluids and other special fluids.

PF4300 Series pumps are compatible with a variety of water-based fluids. These models, which are specifically rated for use with low-lubricity fluids.

Some pump models may require reduced operating pressures when using low-lubricity fluids.

Because of the wide range of fluid characteristics, contact the sales department for a review of any application using non-petroleum based fluids.

Viscosity Specifications

Using fluid with the correct viscosity range is critical to achieving long component life.

Fluid conditions outside the "Optimum" range shown in the table may result in reduced pump output, requiring pressurized inlet conditions. For more information, contact the sales department.

Hydraulic Fluid Viscosity^①

Pump Models	Operating				Start-up ^②		Optimum		
	Minimum		Maximum		SUS	cSt	SUS	cSt	
	SUS	cSt	SUS	cSt					
<i>Fixed Displacement Pumps:</i>									
PF500-10	52	8	1911	413	3706	800	98 to 324	20 to 70	
PF1000-10	59	10	1911	413	3706	800	98 to 324	20 to 70	
PF2000	59	10	1911	413	1911	413	98 to 324	20 to 70	
PF2000 ^②	34	2,3	1911	413	1911	413	98 to 324	20 to 70	
PF3000-10	59	10	1911	413	3706	800	98 to 342	20 to 70	
PF4000-30	34	2,3	1911	413	1911	413	98 to 324	20 to 70	
PF4200-10	34	2,3	1911	413	1911	413	98 to 324	20 to 70	
PF4300-11	31	1,5	927	200	927	200	–	–	
PF6000	34	2,3	1911	413	1911	413	98 to 324	20 to 70	
<i>Mechanical Variable Delivery Pumps:</i>									
PV4000	34	2,3	1911	413	1911	413	98 to 324	20 to 70	
PV6000	34	2,3	1911	413	1911	413	98 to 324	20 to 70	
<i>Hydraulic Variable Delivery Pumps:</i>									
PV6000	34	2,3	1911	413	1911	413	98 to 324	20 to 70	

① Fluid conditions outside the "Optimum" range may result in reduced output, requiring pressurized inlet conditions. Contact the sales department.

② Models with special mounting.

MINIMUM FILTRATION LEVELS

Pump inlet: 150 μ nominal;

Pressure or return line: 25 μ nominal.

While finer filtration levels than these are desirable and will result in longer component life, restricting flow to the pump inlet should be avoided. Minimum recommended inlet conditions must be maintained.

If a system component fails resulting in fluid contamination, it is important to drain and clean the reservoir, all lines, filter screens and all components. Refill with new fluid.

INSTALLATION AND OPERATION

Refer to separate Bulletin PSI.CB for general installation and operating recommendations.

That brochure includes information on mounting, shaft loading, sizing inlet pipe and hose, air bleed procedures and initial start-up. Guidelines for maintenance, repair and trouble-shooting are also included.

PORT DESCRIPTIONS

Dynex pumps are available with outlet ports suitable for use at various pressure ranges. Refer to the appropriate "Specification Table" or "Typical Model Code" to specify the required port.

Contact the fitting manufacturer to ensure the selected fittings are rated for the maximum pump operating pressure.

S.A.E. Straight Thread Ports

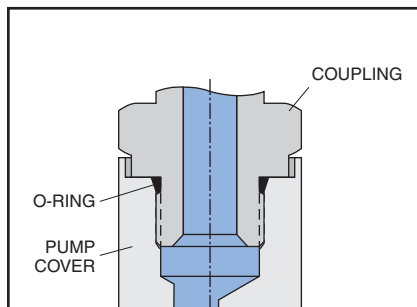

Typical S.A.E. Straight Thread port connection

The Straight Thread connection (S.A.E. J1926/1) is sometimes referred to as an S.A.E. O-ring Boss, or ORB. The port consists of a machined spotface surface, a tapered seal cavity and a straight thread port.

The fitting forms a seal by compressing the o-ring in the seal cavity with the underside of the flanged wrench flat. Some adjustable fittings, such as elbows and tees, use a locknut with a captive backup washer for compression.

S.A.E. Straight Thread ports are not recommended for operation above 8000 psi (560 bar). Also, the maximum pressure of pumps with No. 12 S.A.E. outlet ports may be limited by the pressure rating of the available fitting. Contact the fitting manufacturer for ratings.

Coned and Threaded Ports

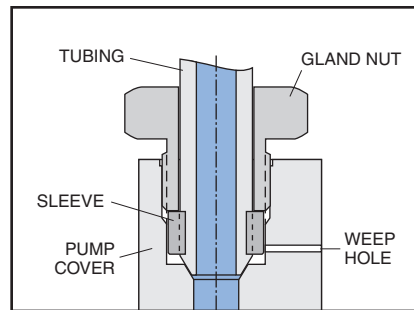

Typical Coned and Threaded port connection

High-pressure pumps are available with coned and threaded outlet ports, which use Autoclave Medium Pressure, Butech M/P, or equivalent fittings.

These fittings provide a metal-to-metal seal with an interference fit, not requiring an o-ring. The gland nut holds the sleeve and tubing against the cone surface.

A weep hole, visible on the outside of the pump cover, acts as an indicator of any abnormal leakage caused by system conditions (i.e., excessive pressure). It allows any fluid which does leak past the sealing surfaces to escape, preventing pressure build-up and possible damage.

British Standard Pipe Ports

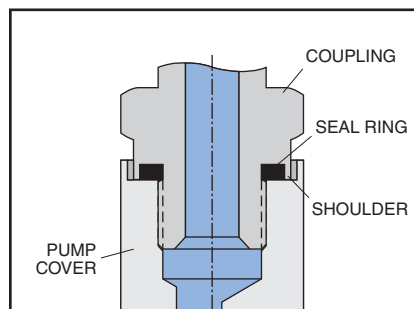

Typical port connection with British Standard Pipe (Parallel) fitting with shoulder

High-pressure pumps are available with flat face ports with British Standard Pipe (B.S.P.) parallel threads (BS 2779 or ISO 228), ideal for use on some European applications.

The fitting forms a seal by compressing a flat elastomer ring on a machined spotface surface. There are several sealing methods for these ports.

The recommended fitting has a recessed seal cavity formed by a shoulder on the underside of the flanged wrench flat (Voss "Peflex", Form B Shoulder Seal; or Parker Type E, "Elastic" Seal; or equivalent).

B.S.P. ports are not recommended for operation above 10 000 psi (700 bar). Contact the fitting manufacturer, to ensure the selected fittings are rated for the maximum pump operating pressure.

S.A.E. 4-Bolt Flange Ports

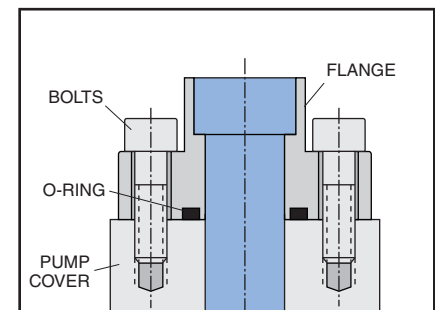

Typical S.A.E. 4-Bolt Flange port connection

Flange connections are often used for higher flows requiring larger diameter tubing. The port consists of an unthreaded port with four bolt holes in a rectangular pattern on a machined face around the port (S.A.E. J518).

A typical fitting consists of a flanged head with a welded tube and a captive flange with bolt holes. A seal is formed by an o-ring in the groove on the underside mounting surface of the flange head. As the flange bolts are alternately tightened, the o-ring is compressed between the flange head and the machined face on the pump.

To make mounting easier in tight spaces a two-piece split-flange is often used.