

Order example:

MCSH – 10 – 60

MODEL

TUBE I.D.

STROKE

Features:

- A table cylinder suitable for short pitch mounting.
- The use of an endless track linear guide produces a table cylinder having excellent rigidity, linearity and non-rotating accuracy.
- Mounting is possible from 3 or 4 directions.

Specification:

Model	MCSH			
Acting type	Double acting			
Tube I.D. (mm)	6	10	16	20
Guide rail width (mm)	5	7	9	12
Port size	M5×0.8			
Medium	Air			
Min. operating pressure	1.2 kgf/cm ² (0.12 MPa)	0.61 kgf/cm ² (0.06 MPa)	0.51 kgf/cm ² (0.05 MPa)	
Max. operating pressure	7.1 kgf/cm ² (0.7 MPa)			
Proof pressure	10.7 kgf/cm ² (1.05 MPa)			
Ambient temperature	−5~+60℃ (No freezing)			
Piston speed	50~500mm/s			
Allowable kinetic energy J (kgf · cm)	0.0125 (0.127)	0.025 (0.25)	0.05 (0.5)	0.1 (1.0)
Lubricator	Not required			
Cushion	Rubber bumper			
Stroke length tolerance	+1.0 0			
Sensor switch	RCE, RCE1			

Table for standard stroke:

Tube I.D.	Stroke (mm)
φ 6,10,16,20	5, 10, 15, 20, 25, 30, 40, 50, 60

Theoretical force:

(Unit: N)

Tube I.D. (mm)	Piston rod (mm)	Operating direction	Piston area (mm ²)	Operating pressure (MPa)		
				0.3	0.5	0.7
6	3	OUT	28.3	8.49	14.2	19.8
		IN	21.2	6.36	10.6	14.8
10	4	OUT	78.5	23.6	39.3	55.0
		IN	66.0	19.8	33.0	46.2
16	6	OUT	201.0	60.3	101.0	141.0
		IN	172.0	51.6	86.0	121.0
20	8	OUT	314.0	94.2	157.0	220.0
		IN	264.0	79.2	132.0	185.0

COMPACT SLIDE

Operating precautions

- 1 Positively do not put fingers between the table and cylinder tube, as they can be caught when the piston rod retracts. If fingers are caught in a cylinder, there is a danger of injury due to the strong cylinder output, and therefore caution must be exercised.
- 2 Operate within the limits of the maximum movable weight and allowable moment.
- 3 When the output of the compact slide will be directly applied to the table, it should be applied along the rod axis. (See drawing below.)
- 4 Be sure to attach a speed controller, and adjust the speed to 500mm/s or less.

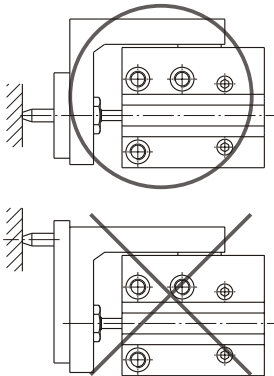

Stroke Direction Backlash

- 1 Since the connection between the piston rod and table is a floating structure, there is a maximum table backlash of 0.15mm in the stroke direction. (See drawing below.)

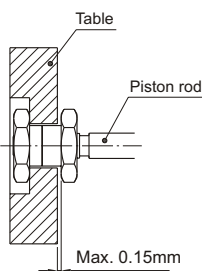

Piston rod and table connection

Operating direction with different pressure ports

- 1 The compact slide can be piped from 3 directions. Confirm the pressure ports and operating direction. (See drawing below.)

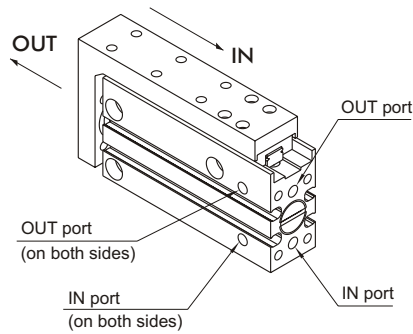

Sensor switch mounting

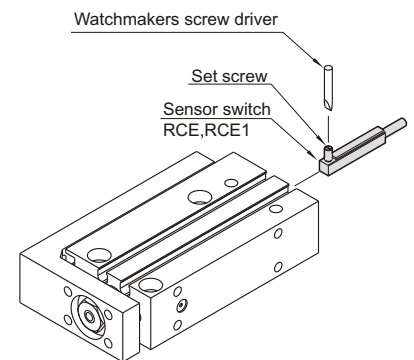

Mounting

Work piece mounting

Work pieces can be mounted on 2 surfaces of the compact slide.

- 1 Since the table is supported by the linear guide, take care not to apply strong impact or large moment, etc. when mounting work pieces.
- 2 Hold the table when fastening work pieces to it with bolts, etc. If the body is held while tightening bolts, etc., the guide section will be subjected to large moment, and there may be a loss of precision.
- 3 For connection with a load having an external support/guide mechanism, select an appropriate connection method and perform careful alignment.
- 4 Use caution, as scratches or nicks, etc. on the sliding parts of the piston rod can cause malfunction and air leakage.

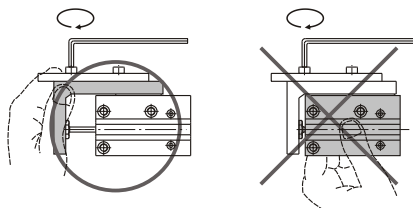

When mounting a compact slide, tighten the screws properly at a torque value within the limiting range.

1. Front mounting

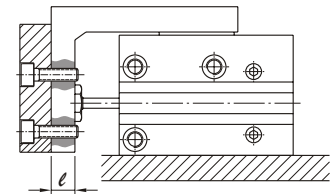

Model	Bolt	Max. torque (Nm)	ℓ (mm)
MCSH-6	M3 × 0.5	1.1	5.5
MCSH-10	M4 × 0.7	2.5	7.5
MCSH-16	M4 × 0.7	2.5	10
MCSH-20	M5 × 0.8	5.1	11

2. Top mounting

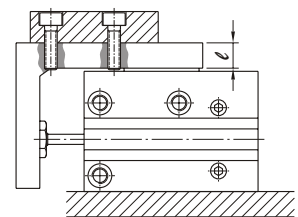

Model	Bolt	Max. torque (Nm)	ℓ (mm)
MCSH-6	M3 × 0.5	1.1	6.5
MCSH-10	M4 × 0.7	2.5	8
MCSH-16	M4 × 0.7	2.5	9
MCSH-20	M5 × 0.8	5.1	9.5

Mounting

When mounting a compact slide, tighten the screws properly at a torque value within the limiting range.

Compact slide mounting

① A compact slide can be mounted from 4 directions. Make a selection suitable for the applicable machinery and work pieces, etc.

Lateral mounting (through holes)

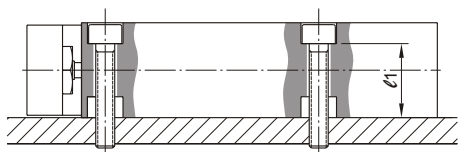

Model	Bolt	Max. torque (Nm)	ℓ 1 (mm)
MCSH-6	M3×0.5	1.1	12.7
MCSH-10	M4×0.7	2.5	15.6
MCSH-16	M4×0.7	2.5	20.6
MCSH-20	M5×0.8	5.1	24.0

Lateral mounting (tapped holes)

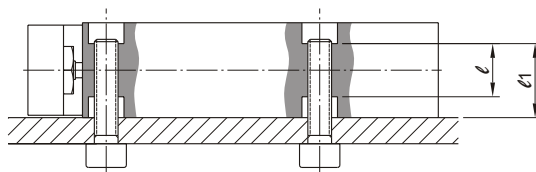

Model	Bolt	Max. torque (Nm)	ℓ 1 (mm)	ℓ (mm)
MCSH-6	M4×0.7	2.5	12.7	9.4
MCSH-10	M5×0.8	5.1	15.6	11.2
MCSH-16	M5×0.8	5.1	20.6	16.2
MCSH-20	M6×1	8.1	24.0	16.0

Vertical Mounting (Tapped Holes)

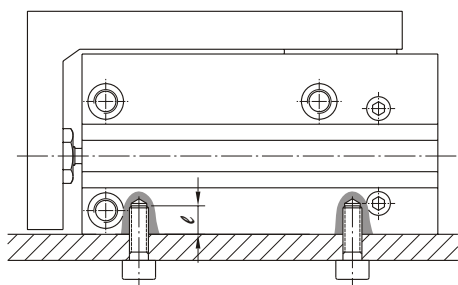

Model	Bolt	Max. torque (Nm)	ℓ (mm)
MCSH-6	M3×0.5	1.1	4.8
MCSH-10	M4×0.7	2.5	6
MCSH-16	M4×0.7	2.5	6
MCSH-20	M5×0.8	5.1	8

Axial Mounting (Tapped Holes)

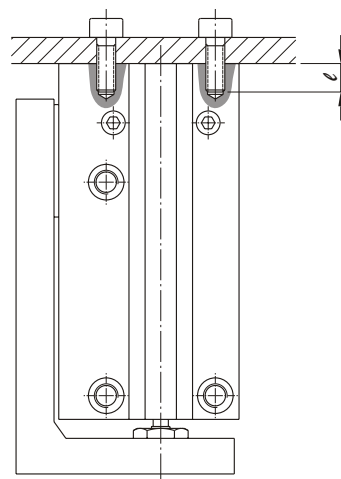

Model	Bolt	Max. torque (Nm)	ℓ (mm)
MCSH-6	M3×0.5	1.1	4.8
MCSH-10	M4×0.7	2.5	6
MCSH-16	M4×0.7	2.5	6
MCSH-20	M5×0.8	5.1	8

Table accuracy

Running parallelism	Stroke (st)	
	5~30	40~60
	0.05mm or less	0.1mm or less

Allowable moment (N·m)

Model	Pitch moment M_p	Yaw moment M_y	Roll moment M_r
MCSH-6	0.47	0.39	0.59
MCSH-10	0.96	0.82	1.37
MCSH-16	1.88	1.59	2.75
MCSH-20	3.14	2.75	5.49

Design precautions

- ❶ Bore size selections cannot be made with the above graphs alone. Perform bore size selections with the model selection method provided on pages 5 and 6.
- ❷ The displacement may increase after the action of an impact load. When the table is subjected to an impact load, there may be permanent distortion of the guide unit and increased displacement.

Table displacement due to pitch moment

Table displacement (arrow) when a load acts upon the section marked with the arrow at the full stroke of the compact slide.

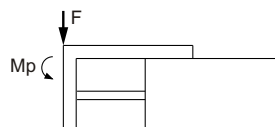

$\phi 6$

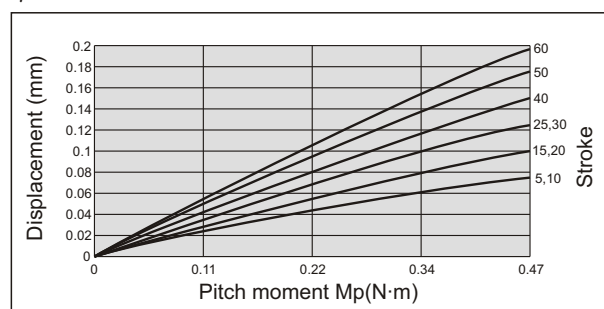

$\phi 10$

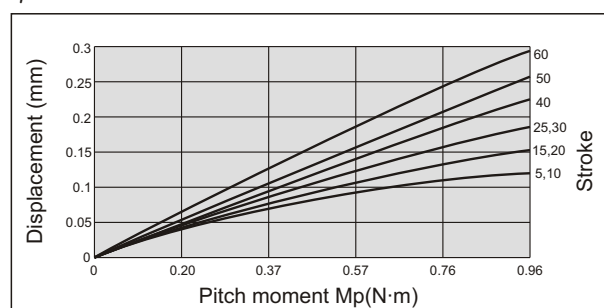

$\phi 16$

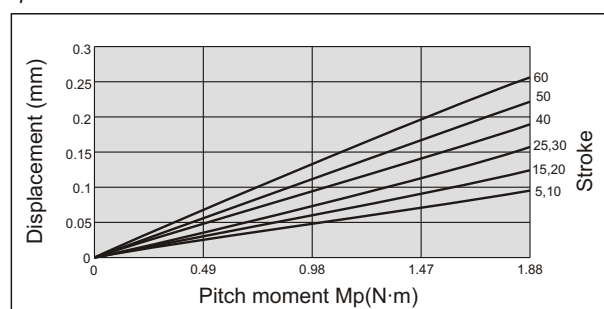

$\phi 20$

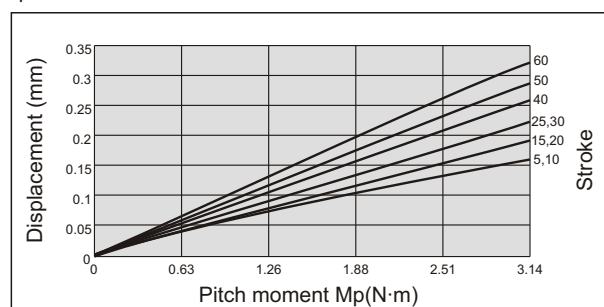

COMPACT SLIDE

Table displacement due to yaw moment

Table displacement (arrow) when a load acts upon the section marked with the arrow at the full stroke of the compact slide.



$\phi 6$

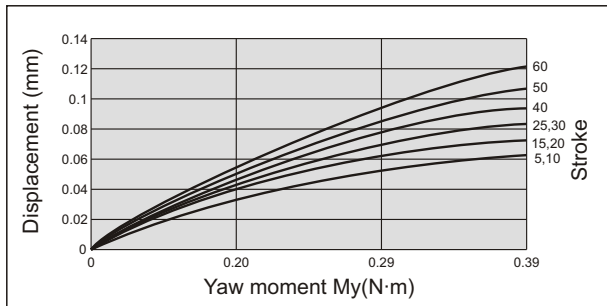

$\phi 10$

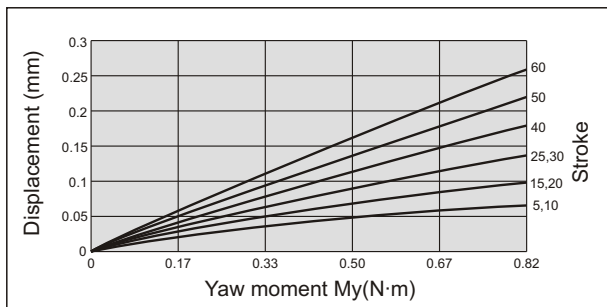

$\phi 16$

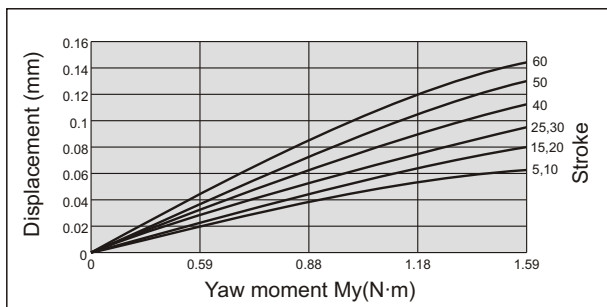

$\phi 20$

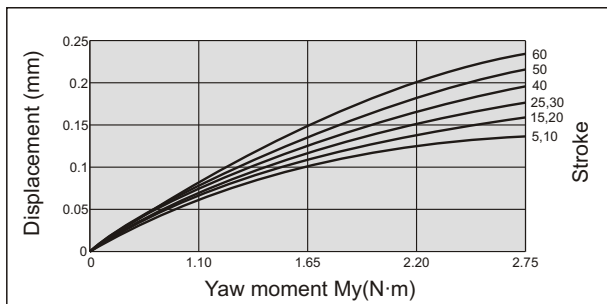
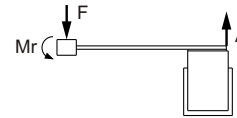
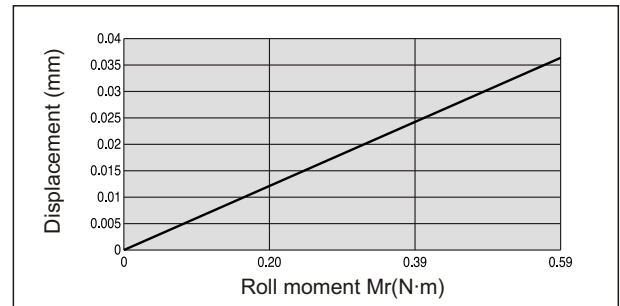

Table displacement due to roll moment

Table displacement (at A) when a load acts upon section F at the full stroke of the compact slide.



$\phi 6$



$\phi 10$

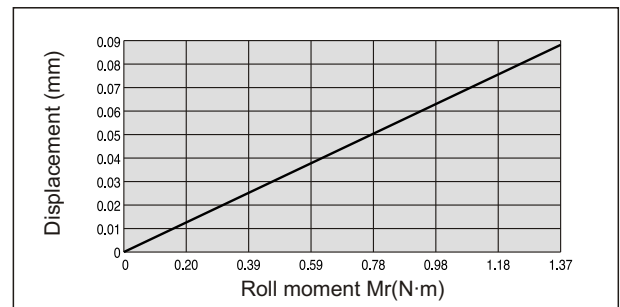

$\phi 16$

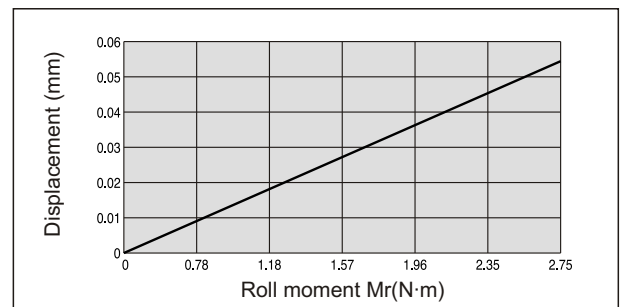

$\phi 20$

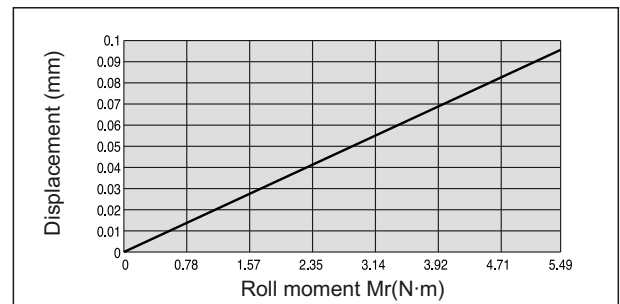

COMPACT SLIDE

⚠ Caution: Separate confirmation of the theoretical output is necessary. Refer to the theoretical output table on page 2.

Selection conditions:

Determine the selection conditions in order, starting from the upper row in the table below, and choose one of the selection graphs to be used. the compact slide.

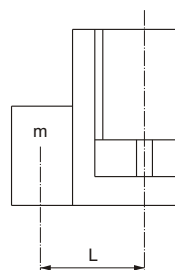
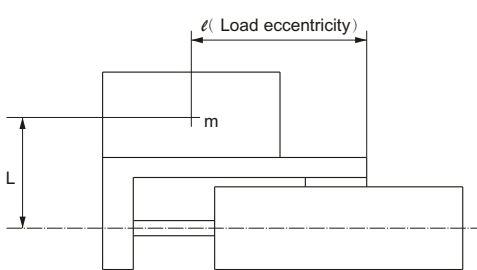
Mounting position	Vertical			Horizontal								
												
Max. speed mm/s	~100	~300	~500	~100			~300			~500		
Load eccentricity l mm	—			50	100	200	50	100	200	50	100	200
Selection graph	1	2	3	4	5	6	7	8	9	10	11	12

※ L : Overhang (the distance from the cylinder shaft center to the load center of gravity)
The direction of L can also be a diagonal direction .
(See drawing at right)

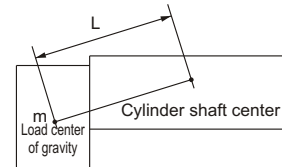

Selection graphs 1 to 3 (Vertical mounting)

Graph 1

Max. speed 100(mm/s) or less

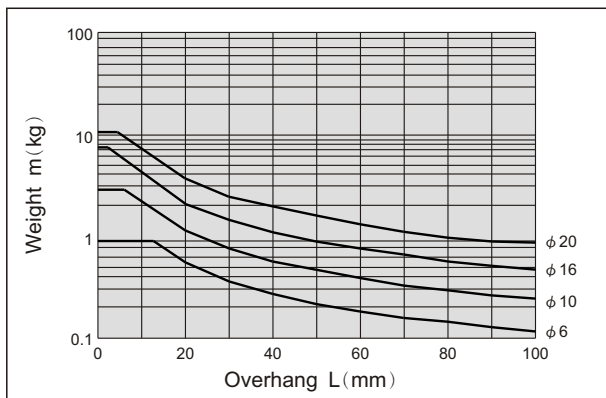

Graph 3

Max. speed 500(mm/s) or less

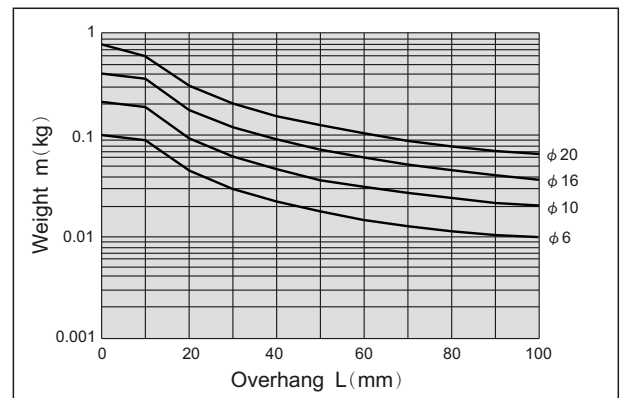

Graph 2

Max. speed 300(mm/s) or less

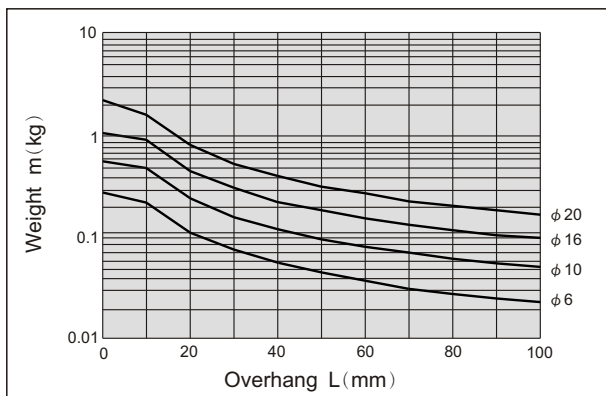

Selection graphs 4 to 12 (Horizontal mounting)

Max. speed 100(mm/s) or less

Max. speed 300(mm/s) or less

Max. speed 500(mm/s) or less

Graph 4 Load eccentricity 50mm

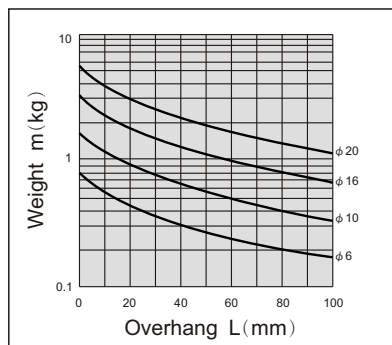

Graph 7 Load eccentricity 50mm

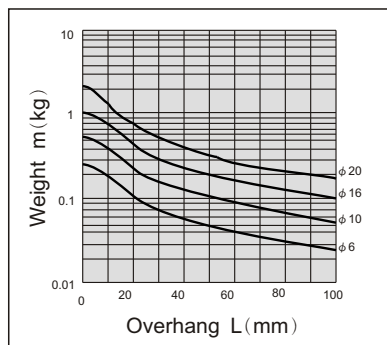

Graph 10 Load eccentricity 50mm

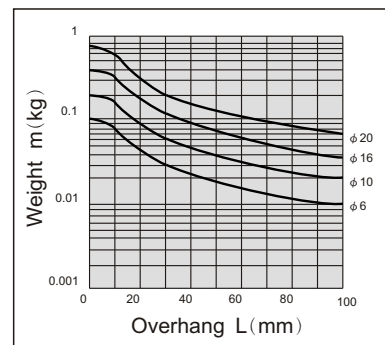

Graph 5 Load eccentricity 100mm

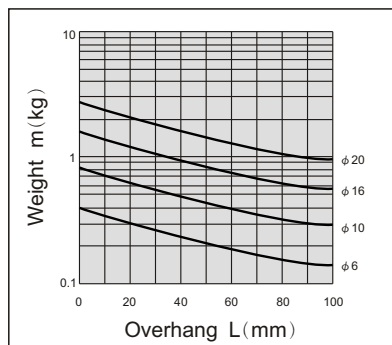

Graph 8 Load eccentricity 100mm

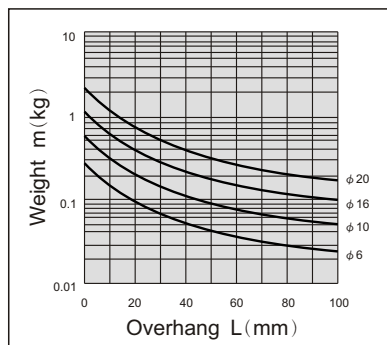

Graph 11 Load eccentricity 100mm

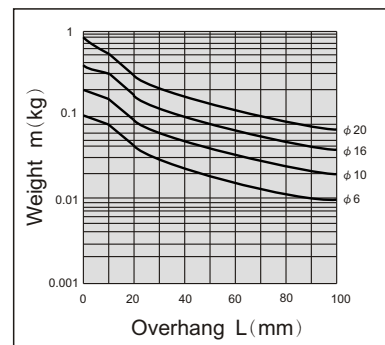

Graph 6 Load eccentricity 200mm

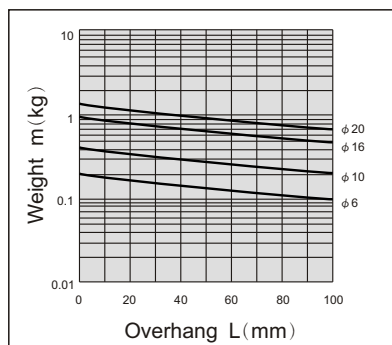

Graph 9 Load eccentricity 200mm

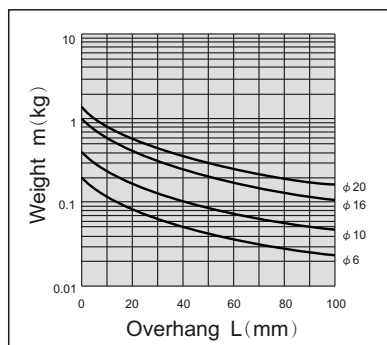

Graph 12 Load eccentricity 200mm

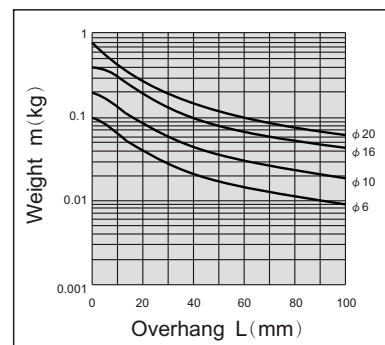

Selection Examples

- ①** Selection conditions:
 Mounting: Vertical
 Maximum speed: 500mm/s
 Overhang: 40mm
 Load weight: 0.1Kg

Refer to Graph 3 based on vertical mounting and a speed of 500mm/s.
 In Graph 3, find the intersection of a 40mm overhang and load weight of 0.1Kg, which results in a determination of $\phi 20$.

- ②** Selection conditions:
 Mounting: Horizontal
 Maximum speed: 500mm/s
 Load eccentricity: 50mm
 Overhang: 30mm
 Load weight: 0.1Kg

Refer to Graph 10 based on horizontal mounting, a speed of 500mm/s and load eccentricity of 50mm.
 In Graph 10, find the intersection of a 30mm overhang and load weight of 0.1Kg, which results in a determination of $\phi 16$.

MCSH Inside structure & Parts list

COMPACT SLIDE



φ 6, φ 10

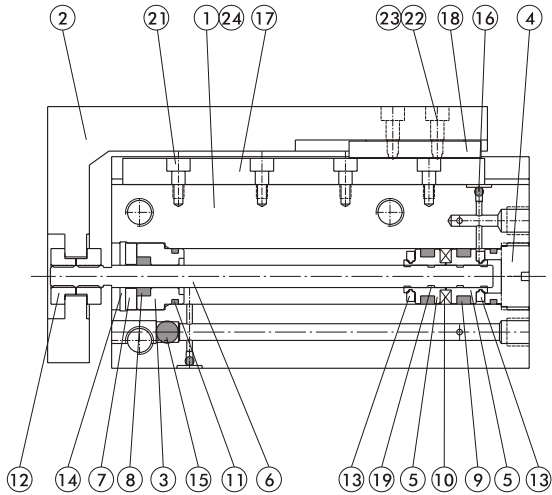

φ 16, φ 20

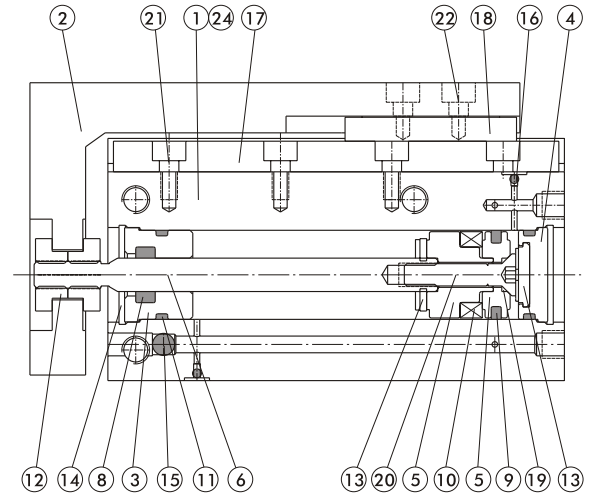

Material

No.	Part name	Tube I.D.				Note
		6	10	16	20	
1	Body	Aluminum alloy				Anodized
2	Table	Aluminum alloy				Anodized
3	Rod cover	Aluminum alloy				Anodized
4	Head cover	Aluminum alloy				Anodized
5	Piston	Aluminum alloy				
6	Piston rod	Stainless steel				
7	Washer	Aluminum alloy				
8	Rod packing	NBR				
9	Piston packing	NBR				
10	Magnet ring	Magnet material				
11	Cover ring	NBR				
12	Rod front nut	Brass				
13	Cushion packing	NBR				
14	C type snap ring for hole	Spring steel				
15	Steel ball A	Stainless steel				
16	Steel ball B	Stainless steel				
17	Linear guide	Stainless steel				
18	Guide seat	Stainless steel				
19	Piston gasket	NBR				
20	Piston bolt	SCM				
21	Hexagon socket head cap screw A	Stainless steel				
22	Hexagon socket head cap screw B	Stainless steel				
23	Round head Phillips screw	Stainless steel				Only for φ 6
24	Hexagon socket head plug	Stainless steel				

$\phi 16$

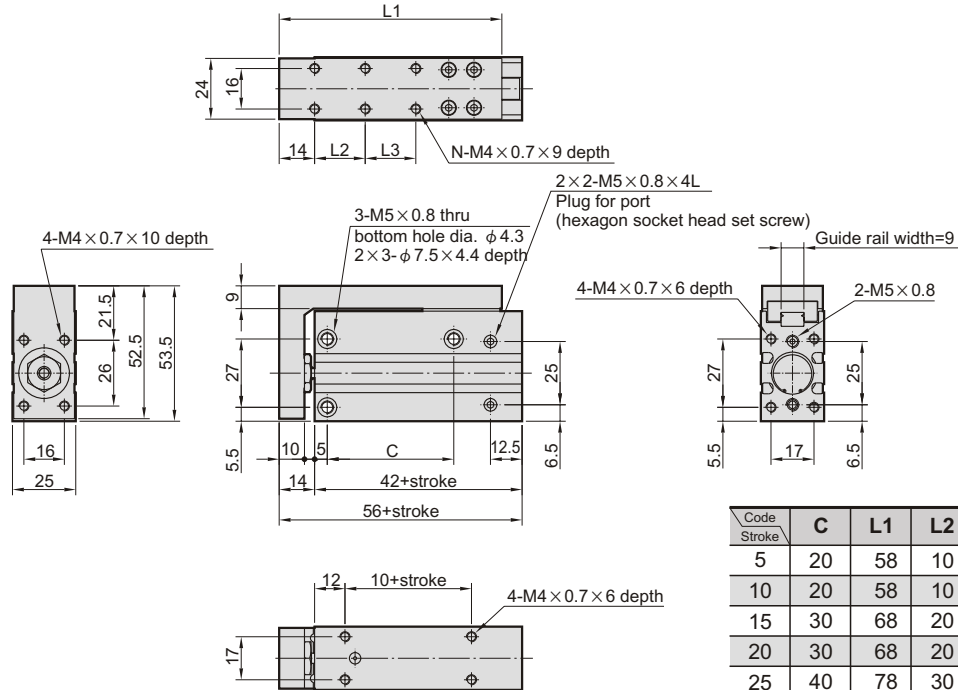

Code Stroke	C	L1	L2	L3	N
5	20	58	10	-	4
10	20	58	10	-	4
15	30	68	20	-	4
20	30	68	20	-	4
25	40	78	30	-	4
30	40	78	30	-	4
40	50	88	20	20	6
50	60	98	25	25	6
60	60	108	30	30	6

$\phi 20$

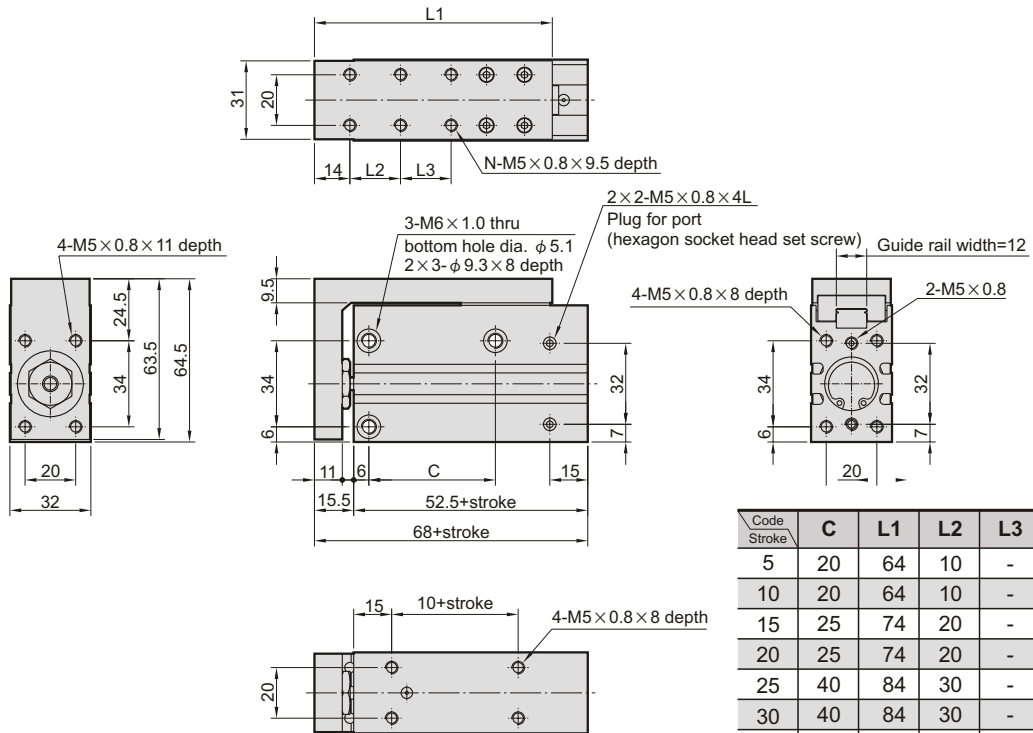

Code Stroke	C	L1	L2	L3	N
5	20	64	10	-	4
10	20	64	10	-	4
15	25	74	20	-	4
20	25	74	20	-	4
25	40	84	30	-	4
30	40	84	30	-	4
40	50	94	20	20	6
50	70	104	25	25	6
60	70	114	30	30	6